



DPD/XPD VMEbus Intel® Core™ Duo Based Single Board Computer

User's Manual



XPD User's Manual Rev. 1.02
Revised to fix JP8 description

July 2007

Dynatem

23263 Madero, Suite C
Mission Viejo, CA 92691
Phone: (949) 855-3235
Fax: (949) 770-3481
www.dynatem.com

Table of Contents

1.	Features	1
2.	Related Documents	3
3.	Hardware Description	5
3.1	Overview	5
3.2	Processor	6
3.3	Chipset	6
3.4	DRAM	7
3.5	Intel 82571EB Dual Gigabit Ethernet Controller	7
3.6	ATI Rage Mobility M1 Graphics Processor	8
3.7	Tundra Universe IID CA91C142D PCI-VMEbus Interface	9
3.8	PCI Mezzanine Card (PMCX) and XMC Expansion	12
3.9	Intel's FW82802A Firmware Hub Holds the System BIOS In Flash Memory	12
3.10	Clock Drivers	12
3.11	Reset Circuitry	13
3.12	Watchdog Timer Operation	14
4.	Installation	15
4.1	Jumper Selectable Options	15
4.2	CompactFlash Drive Installation	17
4.3	PCI Mezzanine Card (PMC) Installation	17
4.4	VMEbus Chassis Installation	17
4.5	Front Panel Connectors and Reset Switch	18

A.	Connector Pin-outs	19
A.1	Front Panel USB Connector (USB1 & USB2)	20
A.2	1000BaseTX Fast Ethernet Front Panel Connector (J1)	20
A.3	CompactFlash Interface Connector (J3)	21
A.4	VMEbus Connectors (P1, P2, and P0)	22
A.5	PCI-X Mezzanine Card Connectors (JN1, JN2, JN3, and JN4) and XMC Connector (J15)	25
B.	BIOS & Setup	31
B.1	Redirecting to a Serial Port	31
B.2	Setup Menus	31
B.3	Navigating Setup Menus & Fields	32
B.4	Main Setup Menu	33
B.5	Exit Setup Menu	34
B.6	Boot Setup Menu	35
B.7	POST Setup Menu	37
B.8	PnP Setup Menu	39
B.9	Super I/O (SIO) Setup Menu	40
B.10	Features Setup Menu	41
B.11	Firmware Setup Menu	42
B.12	Miscellaneous Setup Menu	44
C.	Power and Environmental Requirements	47
D.	XPDPPTB Rear Plug-in I/O Expansion Module for the XPD	49
D.1	XPDPPTB Connector Pin-outs	50

1. Features

The Dynatem XPD is a single-slot 6U VMEbus Single Board Computer (SBC). The XPD offers full PC performance with a Core Duo processor. The XPD is available in two versions: the lower cost DPD for standard industrial applications and the 1101.2 compliant, conduction-cooled RPD with wedgelocks, stiffener bar, and a full board heatsink for rugged applications. When referring to attributes of both versions, we will use the common name XPD. The XPD employs Intel's embedded technology to assure long-term availability.



Features of the XPD include:

- A 1.66 GHz Intel® Core™ Duo processor with 2 MB of L2 cache
- Single-slot VMEbus operation with on-board CompactFlash disk for bootable mass storage and front panel connectors for two USB 2.0 ports, two Fast Ethernet ports, and XPD & PMC I/O
- An IDE port, four RS232 COM ports, PS/2 Mouse & Keyboard, two USB ports, and PMC I/O are routed out to the backplane via the P2 connector
- Two Serial ATA ports, VGA graphics, two Gbit Ethernet ports (Vita 31.1 compliant) and PMC/XMC I/O are routed to the P0 connector

Chapter 1 – Features

- The Intel® E7520 Memory Controller Hub (MCH) and Intel® 6300ESB I/O Controller Hub (ICH) provide high-speed memory control, 16 lanes of PCI Express I/O, integrated I/O like Serial ATA, USB 2.0, IDE supporting Ultra 100 DMA Mode for transfers up to 88.88 MB/sec, and 64 bit PCI-X bus transfers at 66 MHz
- ATI's Rage Mobility M1 VGA Controller
- Two Intel 82571EB Ethernet Controllers with a x4 PCI Express interface, each offering two 10/100/1000BaseTX support; two ports are routed to P0 in compliance with Vita 31.1 for backplane fabric switching while the other two are routed to the front panel
- 2 GB of DDR2-400 DRAM provided on-board
- Tundra Universe IID PCI-VMEbus Interface provides 64-bit VMEbus transfer rates over 30 MB/sec. Integral FIFOs permit write-posting to maximize available PCI and VMEbus bandwidth. Full Slot 1 (System Controller) functionality is provided
- PCI Mezzanine Card (PMC) expansion supports 64 bits @ up to 66 MHz
- A second PCI Mezzanine Card (PMC) expansion supports 64 bits @ up to 66 MHz and can also support an MC module with up to x8 PCI Express
- Secondary IDE port for CompactFlash on-board for flash-based or mechanical mass storage for 1 slot booting
- General Software's Version 6.0 flash-based system BIOS
- PXE for diskless booting over Ethernet
- Programmable watchdog timer for system recovery and a CPLD for LED control, Geographical Addressing, and Built-In Test (BIT) status and control
- Operating System (OS) and driver support, including Windows NT, Embedded NT, XP, QNX, VxWorks, Linux, Solaris, and pSOS+.

2. Related Documents

Listed below are documents that describe the Pentium processor and chipset, and the peripheral components used on the XPD. Either download from the Internet or contact your local distributor for copies of these documents.

The XPD uses the L2400 Low Voltage Core Duo. For information on this processor, go to:

<http://developer.intel.com/design/mobile/core/duodocumentation.htm>

For the ICH component in the 6300ESBchipset get the *Intel® 6300ESB I/O Controller Hub Datasheet*. It is document number 300641-002.

<ftp://download.intel.com/design/intarch/datashts/30064102.pdf>

For information on the E7520 MCH component in the chipset, please go to:

http://www.intel.com/design/chipsets/embedded/e7520_7320.htm

For data sheets on I/O controllers:

- *82571EB Fast Ethernet PCI Controller*
<http://www.intel.com/design/network/products/lan/controllers/82571eb.htm>
- *VMEbus Interface Components Manual*
Tundra Semiconductor Corporation; Universe IID revisions are found at www.tundra.com

The following documents provide information on the PC architecture and I/O:

- *PCI Local Bus Specification, Revision 2.2*
<http://www.pcisig.com/specifications/>
- *PCI-X Specification, Revision 1.0A*
<http://www.pcisig.com/specifications/>
- *System Management Bus Specification (SMBus), Revision 1.1*
<http://www.smbus.org/specs/>
- *Universal Serial Bus Specification*
<http://www.usb.org/developers>

The following documents cover topics relevant to the VMEbus and can be purchased through VITA:

- IEEE Std 1014-1987, *IEEE Standard for a Versatile Backplane Bus: VMEbus*
The Institute of Electrical and Electronic Engineers
345 East 47th Street
New York, NY 10017
(800) 678-4333
- Wade D. Peterson, *The VMEbus Handbook*
VITA
10229 North Scottsdale Road, Suite B
Scottsdale, AZ 85253
(480) 951-8866

Chapter 2 – Related Documents

The following documents are the current draft standards for the PCI Mezzanine Card (PMC) and XMC cards:

- IEEE Draft Std P1386/2.0, *Draft Standard for a Common Mezzanine Card Family: CMC*
The Institute of Electrical and Electronic Engineers
345 East 47th Street
New York, NY 10017
(800) 678-4333
- IEEE Draft Std P1386.1/2.0, *Draft Standard Physical and Environmental Layers for PCI Mezzanine Cards: PMC*
The Institute of Electrical and Electronic Engineers
345 East 47th Street
New York, NY 10017
(800) 678-4333
- VITA 42.0, XMC Switched Mezzanine Card Auxiliary Standard
VITA
10229 North Scottsdale Road, Suite B
Scottsdale, AZ 85253
(480) 951-8866

3.2 Processor

The XPD supports a Core Duo processor at 1.66 GHz. The Intel Core Duo processor with 2 MB of L2 cache is the first dual core processor available for mobile and embedded applications. Features include:

- 667 MHz front side bus (limited by the E7520 FSB).
- On-die 2 MB of L2 cache with Advanced Transfer Cache Architecture.
- On-die, primary 32-KB instruction cache and 32-KB write-back data cache.
- Second-generation Streaming SIMD Extensions 2 (SSE2) and streaming SIMD Extensions 3 (SSE3)
- Supports Intel® Architecture and Dynamic Execution.

For further information on the Core Duo processor available from Intel Corporation, search at:

<http://developer.intel.com/design/mobile/core/duodocumentation.htm>

The Intel® Core™ Duo processor was designed to deliver high, dual processor high performance with low power consumption. With its 65 nm processing technology and 2 MB of L2 advanced transfer cache, the Core Duo offers more performance per Watt. The Thermal Design Power (TDP) is 15 W. Advanced power management included Enhanced Intel SpeedStep Technology are supported. SpeedStep enables clock and core voltage throttling based on temperature or processor loading.

The processor's 667 MHz Front Side Bus utilizes a split-transaction, deferred reply protocol. The FSB uses a Source-Synchronous Transfer (SST) of address and data to improve performance by transferring data four times per bus clock. The address bus can deliver addresses twice per clock cycle. Together, the 4X data bus and 2X address bus provide a data bus bandwidth of up to 5.33 GB/second.

3.3 Chipset

The Intel® E7520 Memory Controller Hub (MCH) and Intel® 6300ESB I/O Controller Hub (ICH) chipset provide memory control, mass storage and basic I/O, and standard PC system resources including the real time clock, NV-RAM, timers, thermal management, and interrupt management. Also, the MCH provides 24 lanes of PCI Express expansion (16 of which are implemented on the XPD) for high-speed expansion through the two dual 1000BaseTX controller chips and the XMC site.. The ICH supports a 32 bit @ 33 MHz PCI bus, to support the Universe VMEbus interface controller and the ATI Rage Mobility M1 graphics chip, and a 64 bit @ 66 MHz PCI-X bus for user I/O expansion through the two PMC sites. The ICH also provides a Low Pin Count (LPC) interface for the BIOS flash chip and for Super I/O and an SMBus interface for on-board resources like the DRAM circuit's SPD PROMs and the thermal monitors.

The MCH supports a base system bus frequency of 200 MHz. The address and request interface is double pumped to 400 MHz while the 64-bit data interface (+ parity) is quad pumped to 800 MHz. This provides a matched system bus address and data bandwidth of 6.4 GB/s. The E7520 (MCH) provides a 400 MHz interface to DDR2 RAM (72 bits wide with ECC). The XPD can be populated with one or two banks of DRAM for 1 GB or 2 GB of total memory respectively. Each bank is serviced by a separate channel from the MCH that function in lock-step mode.

Memory controller features include:

- Memory mirroring allows for two copies of all data in the memory subsystem (one on each channel) to be maintained.
- Hardware periodic memory scrubbing, including demand scrub support.

- Retry on uncorrectable memory
- ECC is supported
- DDR2-400 DRAM is supported on-board

The 6300ESB I/O Controller Hub (ICH) provides most of the XPD's on-board I/O and it's the XPD's PCI-X expansion bridge. The ICH is designed as a low-power, high-performance I/O hub that features:

- 64-bit @ 66 MHz PCI-X expansion that is used on the XPD for the two on-board PMC-X slots.
- Four USB 2.0 compliant ports: two of which are routed to the front panel while the other two are routed to the P2 connector to the backplane.
- Integrated IDE controller supports Ultra 100 DMA Mode Transfers up to 100 MB/sec read cycles and 88.88 MB/sec write cycles for a CompactFlash drive on-board and a primary IDE port that is routed through P2 to the XPDPTB
- Two Serial ATA ports providing 150 MB/sec data rates are routed through P0
- Standard PC functionality like a battery-backed RTC and 256-bytes of CMOS RAM, Power Management Logic, Interrupt Controller, Watchdog Timer, AC'97 CODEC, Integrated 16550 compatible UART's, and multimedia timers based on the 82C54

For further information, see the documents referenced in Section 2

3.4 DRAM

The XPD supports two 72-bit wide, DDR2-400 memory interface channels with a memory bandwidth of 6.4 GB/s with ECC. The XPD can be populated to support 1GB or 2GB of DRAM.

3.5 Intel 82571EB Dual Gigabit Ethernet Controller

The XPD supports two Intel® 82571EB Gigabit Ethernet Controllers, one provides two Vita 31.1 compliant Gigabit LAN ports to the backplane while the other provides two that are accessible from the front panel. The 82571EB is a single, compact component with two fully integrated Gigabit Ethernet Media Access Control (MAC) and physical layer (PHY) ports. This device uses the PCI Express* architecture (Rev. 1.0a), and also enables a dual-port Gigabit Ethernet implementation in a very small area, which is useful for embedded designs with critical space constraints. The Intel 82571EB Gigabit Ethernet Controller provides two IEEE 802.3 Ethernet interfaces for 1000BASE-T, 100BASE-TX, and 10BASE-T applications. In addition to managing MAC and PHY Ethernet layer functions, the controller manages PCI Express packet traffic across its transaction, link, and physical/logical layers.

The Intel 82571EB Gigabit Ethernet Controller for PCI Express is designed for high performance and low memory latency. The device is optimized to connect to the E7520 MCH using four PCI Express lanes. Alternatively, the controller can connect to an Input/Output (I/O) Control Hub (ICH) that has a PCI Express interface. Wide internal data paths eliminate performance bottlenecks by efficiently handling large address and data words. Combining a parallel and pipelined logic architecture optimized for Gigabit Ethernet and for independent transmit and receive queues, the controller efficiently handles packets with minimum latency. The controller includes advanced interrupt-handling features and uses efficient ring-buffer descriptor data structures, with up to 64 packet descriptors cached on chip. A large 48 KByte per port on-chip packet buffer maintains superior performance. In addition, using hardware acceleration, the controller offloads tasks from the host, such as checksum calculations for transmission control protocol (TCP), user datagram protocol (UDP), and Internet protocol (IP); header and data splitting; and TCP segmentation.

The Intel 82571EB offers the following features:

- 10, 100, and 1000BaseTX support with auto-negotiation
- Uses x4 PCI Express from MCH
- Dual 48 KB configurable RX and TX packet FIFOs
- Built-in Phyceiver
- Serial EEPROM for non-volatile Ethernet address storage

Both 10/100/1000BaseTX ports of one 82571EB device are brought out to the P0 backplane connector in compliance with the VITA 31.1 specification. VITA 31.1 permits fabric switching on the backplane where 31.1 compliant SBC's can communicate with each other and with an external network through switch modules that are located at either end of the backplane. Optionally these two 1 Gb Ethernet ports are brought to industry standard RJ-45 connectors on Dynatem's rear I/O plug-in module (XPDPTB).

The two Ethernet ports provided by the DPD's 2nd 82571EB are accessible from the front panel.

Technical documents on Intel's 82571EB Dual Gigabit Ethernet Controller are available at:
http://www.intel.com/design/network/products/lan/docs/82571eb_docs.htm

3.6 ATI Rage Mobility M1 Graphics Processor

The ATI Rage Mobility M1 processor generates VGA graphics which are routed to the P0 backplane connector. A VGA connector is provided by the optional XPDPTB rear-I/O module.

The Rage Mobility M1's features include:

- Supports both independent displays at 1280x1024, 24bpp, 60Hz in 64-bit, and 1024x768, 24bpp, 60Hz in 32-bit (see mode tables for details).
- Primary display path supports VGA and accelerated modes, video overlay, hardware cursor, hardware icon (128x128), and 24-bit palette gamma correction.

The Rage Mobility M1 offers low power graphics for limited GUI purposes. It attaches to the system via the ICH's 32 bit @ 33 MHz PCI bus.

ATI Rage Mobility M1 Signal	PCI Bus Connection
Bus	PCI
IDSEL	AD17
REQ#	REQ1#
GNT#	GNT1#
INTR#	INTB#

3.7 Tundra Universe IID CA91C142D PCI-VMEbus Interface

The PCI-VMEbus interface, based on the Tundra Universe IID CA91C142D, offers the following features:

- High-performance 64-bit VMEbus interface.
- Integral FIFOs for write-posting allow the Universe IID to quickly relinquish the bus.
- Programmable DMA controller with linked list support.
- Full VMEbus system controller functionality.
- Complete VMEbus address and data transfer modes: A32/A24/A16 master and slave; D64 (MBLT)/D32/D16/D08 master and slave.

The block diagram of the PCI-VMEbus interface is shown below:

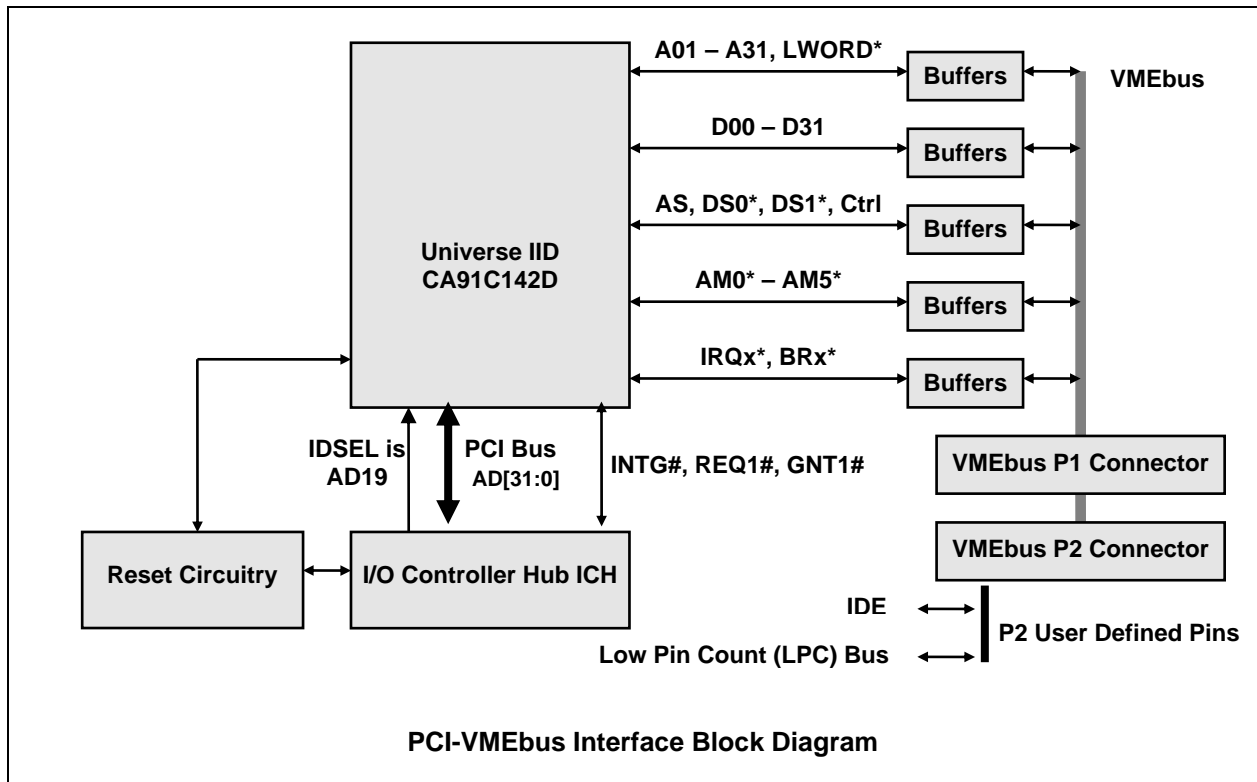

Chapter 3 – Hardware Description

As shown in the block diagram, several peripheral signals are routed to the user-defined pins of the VMEbus P2 connector: the IDE bus and the LPC bus which routes to a Super I/O chip on the XPDPTB rear plug-in card for I/O expansion. The VMEbus P1 and P2 connector pin-outs are given in Appendix A.

The Universe IID CA91C142D can act as a PCI bus initiator (master) or target (slave), and a VMEbus master or slave. The Universe IID is capable of generating interrupts on the VMEbus, and can act as a VMEbus interrupt handler. The Universe IID provides full VMEbus system controller functionality. The XPD reset circuitry is tied to the Universe IID, since the XPD can generate the VMEbus SYSRESET* signal as well as be reset by another VMEbus board that asserts the SYSRESET* signal. The XPD reset circuitry is discussed in detail in Section 3.12.

This section is intended to supplement the VME-to-PCI Bus Bridge Manual User Manual (downloadable from www.tundra.com), which contains comprehensive descriptions of the operation and programming of the Universe IID. That manual provides the necessary information to understand the operating modes of the Universe IID:

- XPD-initiated transfers (PCI slave, VMEbus master).
- Other VMEbus master-initiated transfers (PCI master, VMEbus slave).
- DMA controller transfers (PCI master, VMEbus master).
- VMEbus interrupt generation.
- VMEbus interrupt handling.
- System controller functionality.
- Register programming via the PCI bus and the VMEbus.
- Coupled and uncoupled transfers between the PCI bus and the VMEbus.
- 4 mailboxes and 8 semaphores.
- VMEbus arbitration.

The Universe IID Control and Status Registers (UCSRs) are used for the configuration of the Universe IID. These registers form a 4 KB block, divided into three groups:

- PCI Configuration Space (PCICS).
- Universe IID Device Specific Status Registers (UDSRs).
- VMEbus Control and Status Registers (VCSRs).

These registers are accessible (to varying degrees) via three address spaces:

- PCI Configuration Space – Only the PCICS register block is accessible in this space.
- PCI Memory Space – The entire 4 KB UCSR block is accessible in this space.
- VMEbus A32/A24/A16 Space – The entire 4 KB UCSR block is accessible in this space.

During initialization, the system BIOS maps PCI peripherals that require space beyond the PCI configuration space into the memory space or I/O space. The Universe IID UCSR block is 4 KB in size and must be aligned on a 64 KB boundary. The total I/O space of an Intel processor is 64 KB and many of the common PC peripherals are found in the first 1 KB of this space. Thus, a request for a 64 KB block of I/O space for the Universe IID registers would be denied by the system BIOS, leaving the Universe IID unmapped. To avoid this situation, the Universe IID offers a power-up option to map its registers into the memory space. This is accomplished on the XPD by tying the VA[1] line high via a pull-up resistor.

There are two mechanisms to access the UCSR block from the VMEbus. The first is the VMEbus Register Access Image (VRAI) method, which is defined by the following registers in the Universe IID *User's Manual*:

Field	Register Bits	Description
Address Space	VAS in Table A.76	A32, A24, or A16
Base Address	BS[31:12] in Table A.77	Lowest address in the 4 KB slave image
Slave Image Enable	EN in Table A.76	Enable VMEbus Register Access Image
Mode	SUPER in Table A.76	Supervisor and/or Non-Privileged
Type	PGM in Table A.76	Program and/or Data

The reset state of the VAS, BS[31:12], and EN fields can be configured as power-up options. On the XPD, all of these fields reset to 0. Thus, the VRAI method must be configured and enabled by accessing the Universe IID registers in the memory space.

The second mechanism for accessing the UCSR block from the VMEbus is the CS/CSR method, which is defined by the following registers in the Universe IID section of the *User's Manual*:

Field	Register Bits	Description
Base Address	BS[23:19] in Table A.84	Base address of Universe IID 512 KB slot
Slave Image Enable	EN in Table A.78	Enable CS/CSR image

The BS[23:19] and EN fields reset to all 0s, and the EN bit can be set by the VME64 Auto ID process. Thus, the CR/CSR method must be configured by accessing the Universe IID registers in the memory space.

The PCI signals specific to the Tundra Universe IID CA91C142D are routed from the PCI bus of the ICH and they are shown below:

Tundra Universe IID CA91C142D Signal	PCI Bus Connection
Bus	PCI
IDSEL	AD16
REQ#	REQ0#
GNT#	GNT0#
LINT0#	INTA#
LINT1#	Pulled Up

3.8 PCI-X Mezzanine Card (PMCX) and XMC Expansion

The XPD supports two PCI-X Mezzanine Card (PMC-X) sites on-board. Site #1 also supports x8 XMC cards. Site #1 routes I/O from J14 out through the P2 connector (please see Appendix A) or it can be accessed from the front panel. Site #2 routes I/O from J24 to the P0 backplane connector and/or to the front panel.

3.9 Intel's FW82802AC Firmware Hub Holds the System BIOS In Flash Memory

The Intel FW82802AC uses a 5-pin interface and provides 1 MByte of flash memory for the system BIOS. This device can fill the 1 MB real mode memory map so only a portion its upper 256 MB is used. The FW82802AC's 1 MB of memory space is segmented into sixteen parameter blocks of 64 KB each. The XPD powers up into real mode and the BIOS is eventually shadowed into system DRAM after booting through the BIOS.

The ICH provides the 5-pin interface to the E82802AC. The upper 256 KB of the E82802AC is located from 000C0000 - 000FFFFFF and its full 1 MB of memory is aliased from FFF00000 – FFFFFFFF where it can be fully accessed after booting up through the BIOS.

Here's a link to a datasheet for the 82802AC:

<ftp://download.intel.com/design/chipsets/datashts/29065804.pdf>

3.10 Clock Drivers

The clock driver circuitry is shown below:

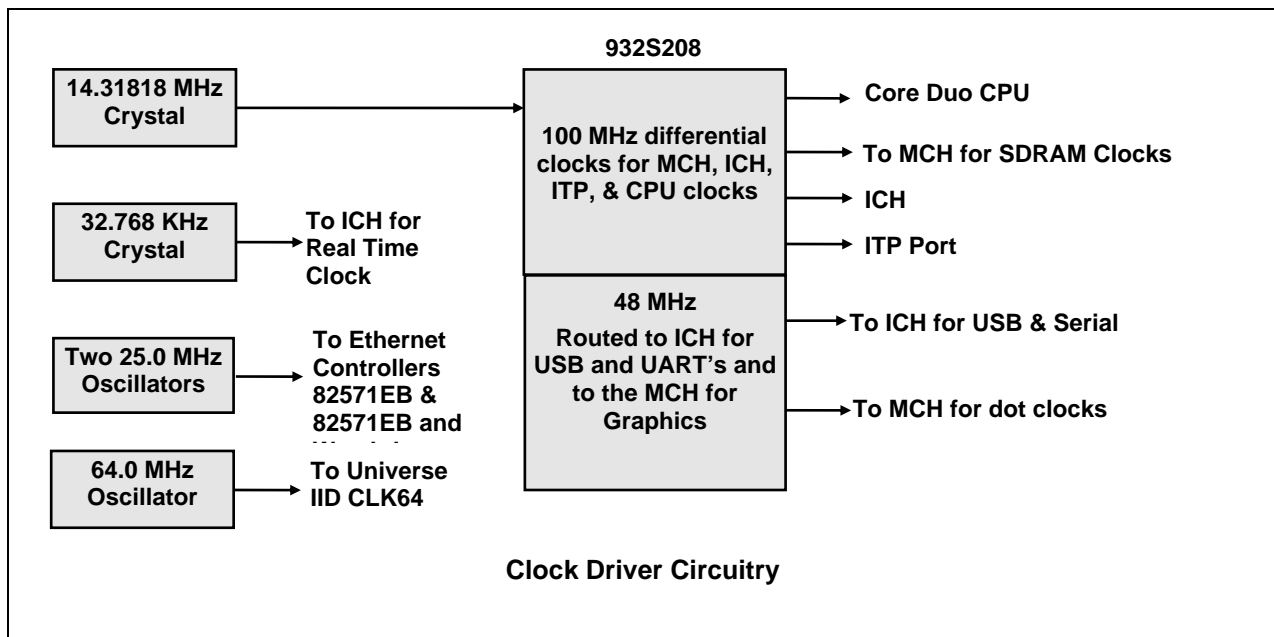

The clocks are generated by the 932S208, which is driven by a 14.31818 MHz crystal. DRAM clocks are synthesized by the MCH and Hub Interface and PCI(-X) clocks are produced by the ICH. A 32.768 KHz Crystal drives the Real Time Clock (RTC) on the ICH. The Fast Ethernet port provided to the front panel by the 82571EB and the two 1 Gb Ethernet ports provided to the backplane by the 82571EB require separate 25.0 MHz oscillators (one of the two oscillators is also used for the watchdog timer clock). A 64.0 MHz oscillator drives the Universe IID CA91C142D VMEbus circuitry.

3.11 Reset Circuitry

The reset circuitry is shown below:

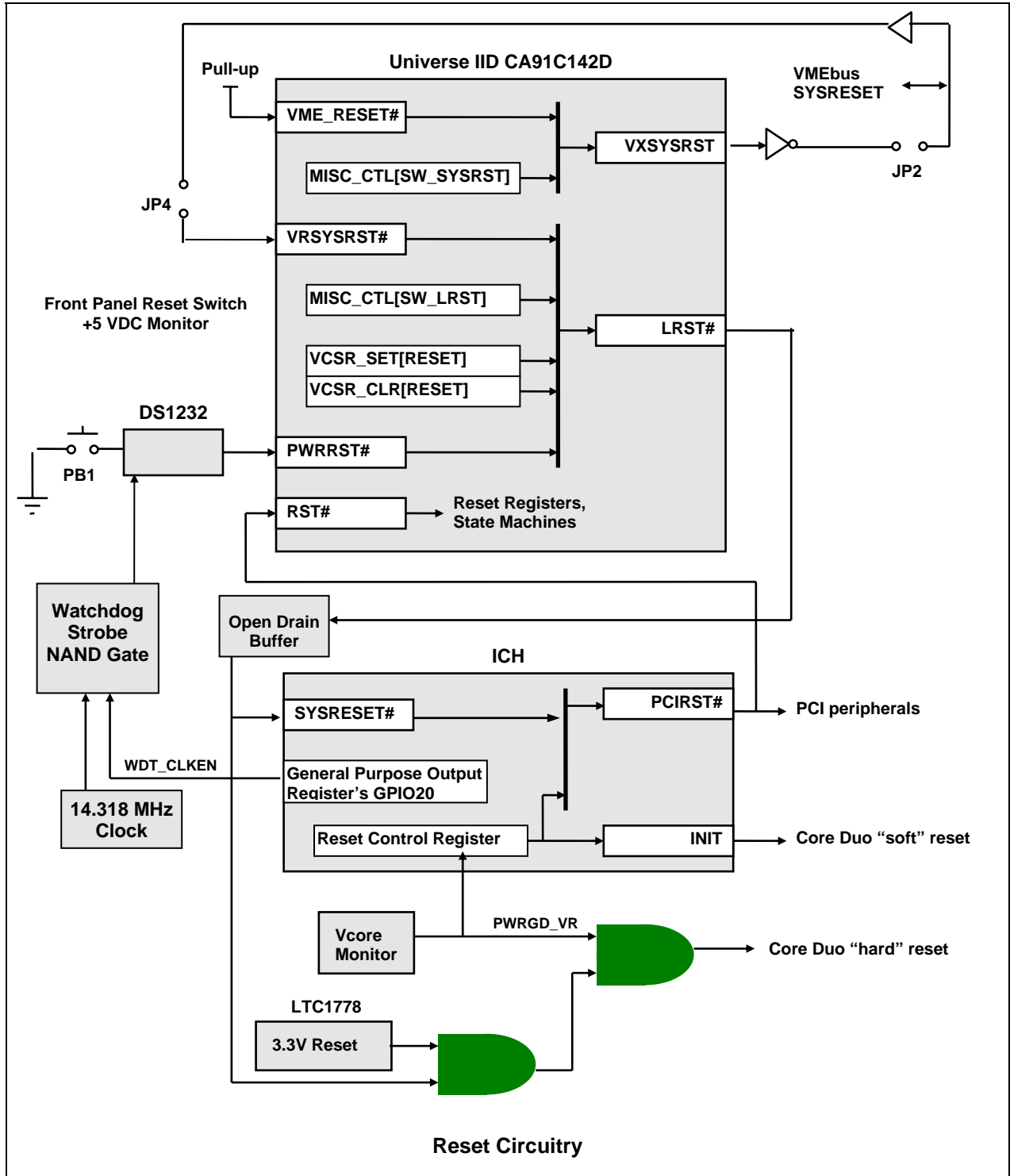

Chapter 3 – Hardware Description

There are eight ways to perform a hard reset of the XPD:

- The DS1232 senses that the +5 VDC supply has dropped too low, asserting a PWROK signal to the ICH. This signal resets the processor and the Chipset and, ultimately, all PCI and PCI-X peripherals. The output of the DS1232 runs through the Universe IID (If the board is delivered without the VMEbus interface circuitry (the XPD) this path is replaced with a bypass 0 ohm resistor).
- A DS1233 monitors the on-board 3.3 VDC, regulated from the 5.0 VDC off the backplane, and provides proper power sequencing for the CPU.
- The local on-board voltage regulator for the CPU's core voltage will generate a reset if its output voltage is out of range through signal PWRGD_VR.
- The front panel reset switch, PB1, is pressed, which also asserts a PWROK signal from the DS1232 and resets the XPD.
- Another VMEbus board asserts SYSRESET*, which asserts the Universe IID VRSYSRST# input and, if Jumper SW1-1 is closed, will reset the XPD.
- The SW_SYSRST bit in the MISC_CTL register of the Universe IID is set by code running on the XPD processor. This asserts the VMEbus SYSRESET* signal if SW1-2 is closed. If SW1-1 is open the XPD can reset the VMEbus without resetting itself.
- The SW_LRST bit in the MISC_CTL register of the Universe IID is set by code running on the XPD processor. This performs a local hard reset, via signal LRST#, of the XPD board circuitry. If SW1-2 is open LRST# will reset the XPD without asserting a VMEbus SYSRESET* signal.
- Another VMEbus master sets the RESET bit in the VCSR_SET register of the Universe IID over the VMEbus. In this case the LRST# signals remains asserted until the RESET bit of the VCSR_CLR register of the Universe IID is set by another VMEbus master over the VMEbus.
- The Reset Control Register in the ICH can be set appropriately by code running on the XPD processor.
- Let the watchdog timer time out; see Section 3.12 below.

For further information on the peripherals that play a part in the reset circuitry, refer to ICH datasheet that's referenced in Section 2.

3.12 Watchdog Timer Operation

The XPD's DS1232 if the watchdog timer is enabled and times out.

The XPD's watchdog timer is controlled by one general-purpose output line (GPIO20) that is asserted by the ICH. The DS1232 has a strobe input pin that must see an active clock. If no clock pulse is generated to the pin within 500 milliseconds, the entire XPD board will be reset. As long as GPIO20 is high, a 14.31818 MHz clock will be present at the strobe input.

To use the watchdog timer, drive GPIO20 low, thereby turning off the 14.31818 MHz clock to the DS1232's strobe input, and write a software routine that will bring GPIO20 high before 500 milliseconds elapses. GPIO20 is controlled by bit 20 in the ICH's GP_LVL register. GPIO20 reflects the status of bit 20: GPIO20 is high if bit 20 is at logic 1 and it is low if bit 20 is at logic 0. GPIO20 is high at reset so the watchdog timer will only be activated when the user drives bit 20 of the GP_LVL register low. For instructions on programming the GP_LVL register, refer to the *Intel® 6300ESB I/O Controller Hub Data Sheet* from Intel Corporation, Document # 300641-002.

4. Installation

The following sections cover the steps necessary to configure the XPD and install it into a VMEbus system for single-slot operation. This chapter should be read in its entirety before proceeding with the installation.

4.1 Selectable Options

This section explains how to set up user configurable jumpers and how to install CompactFlash drives and PMC modules.

The XPD is shipped in an antistatic bag. Be sure to observe proper handling procedures during the configuration and installation process, to avoid damage due to electrostatic discharge (ESD).

The XPD contains eight jumpers. JP3 is located near JN1 for the second PMC site. Jumpers JP1 through JP8 (minus JP3) are arranged in order as shown below:

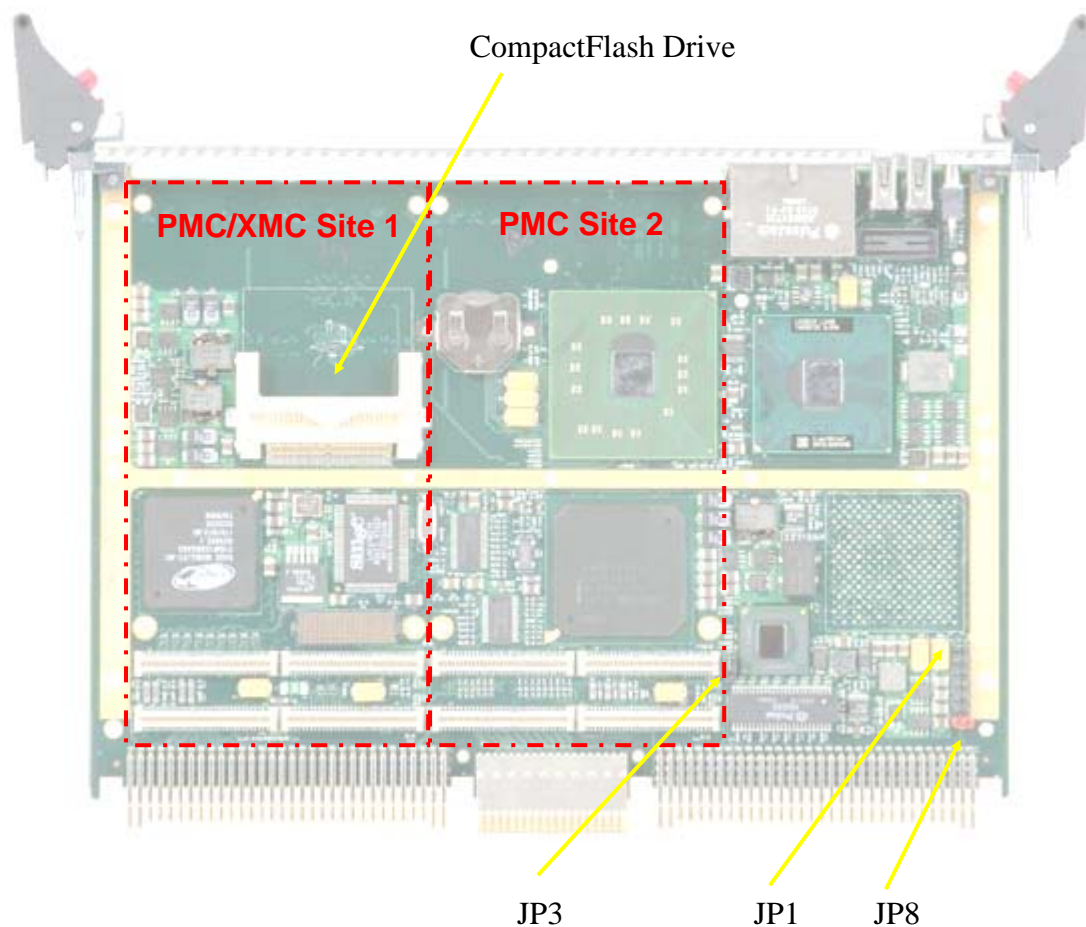

Chapter 4 – Installation

The XPD offers a number of user configurable hardware options.

Jumpers	Description
JP1	VMEbus Slot 1 Controller when open
JP2	XPD drives SYSRESET to the VMEbus when closed
JP3	Determines VIO for the two PMC sites (1 – 2 for 3.3 VDC; 2 – 3 for 5.0 VDC)
JP4	XPD is reset by the VMEbus SYSRESET when closed
JP5	Close momentarily to flush RTC and NV-RAM and revert to BIOS defaults
JP6	Bit Control 1 (grounded when shunted)
JP7	Bit Control 0 (grounded when shunted)
JP8	MUST STAY OPEN (on-board BIOS is disabled when closed)
SW2-1 through SW2-4	DDC Routing for DVI-I Interface (set at the factory)

JP2 lets an XPD SYSRESET reset the VMEbus when closed. When open, the XPD cannot drive a SYSRESET to other modules on the VMEbus. The Universe IID only drives SYSRESET when the XPD is a Slot 1 Controller.

VMEbus SYSRESET Out Selection	JP2
XPD Won't Drive SYSRESET to the VMEbus	Open
XPD Drives SYSRESET to the VMEbus	Closed

VMEbus SYSRESET Out Selection

When a VMEbus module occupies slot 1 of the VMEbus chassis (the slot to the extreme left), it must operate as system controller (act as multiprocessing arbiter and generate utility bus signals). JP1 configures the VMEbus System Controller functionality of the Universe IID, as shown below:

VMEbus System Controller	JP1
Enabled	Open
Disabled	Closed

VMEbus System Controller Configuration

Jumper JP3 selects the VIO routed to the XPD's two PMC modules. The VIO pins determine the signaling voltage on the PMC modules' PCI interface. Refer to the PMC modules' reference manuals to ascertain the recommended VIO. Shunting pins 1 & 2 of JP1 provides a VIO of 3.3 VDC. Shunting pins 2 & 3 routes 5 VDC to the VIO pins on the PMC modules.

VIO Voltage Level	JP3
3.3 VDC	1-2
5 VDC	2-3

Battery Voltage Supply Selection

JP4 lets VMEbus SYSRESET reset the XPD when closed. When open, a VMEbus SYSRESET from other modules will not reset the XPD.

VMEbus SYSRESET In Selection	JP4
XPD Won't Receive SYSRESET from the VMEbus	Open
XPD Receives SYSRESET from the VMEbus	Closed

VMEbus SYSRESET In Selection

Jumper JP5 is provided for clearing the NVRAM. If BIOS parameters are modified and the XPD goes into a failure mode, default variables can be restored by closing JP5 for roughly 15 seconds.

4.2 CompactFlash Drive Installation

The XPD supports a bootable CompactFlash Drive for booting up into an Operating System (OS) while occupying only one slot in the VMEbus chassis. Connector J3 is a Type II CompactFlash connector and is used for this purpose. J3 is located below PMC site 1.

4.3 PCI Mezzanine Card (PMC) Installation

The XPD supports two PMC add-on module sites that let the user expand the XPD’s local I/O with PCI Mezzanine Cards (PMC) or PMCX (PMC modules capable of PCI-X transfers) modules. The PMCX sites are backwards compatible and can support any modules from 32-bit PMC cards at 33 MHz to 64-bit PMCX modules at 66 MHz.

The PMCX sites on the XPD are routed from the ICH’s PCI-X bus interface which is 64 bits wide and has a maximum clock rate of 66 MHz.

PMCX sites	Available Data Rates with VIO = 5 V (JP3 is shunted between pins 2 & 3)	Available Data Rates with VIO = 3.3 V (JP3 is shunted between pins 1 & 2)
1 & 2	33 MHz	33 MHz and 66 MHz

The General Software BIOS will determine during startup what the status of the PCI-X bus. The BIOS monitors the following pins that are routed to the ICH: PCIXCAP (PCX-X capable) and M66EN (66 MHz capable). The user’s manual on your PMC(X) modules will tell you how PCIXCAP (JN1, pin 39) and M66EN (JN2, pin 47) are configured. Since both sites share the same bus, JP3 sets the VIO voltage for both sites and the bus will only clock as fast as the slower PMC card.

Conventionally PMC connectors have four designators: JN1 – JN4. JN1 & JN2 provide all the signals necessary for 32-bit PCI transactions, JN3 has the 32 additional data lines required for 64-bit transfers, and JN4 routes I/O off the module for possible backplane access (see Section A for J14 to P2 and J24 to P0 backplane PMCX I/O routing). The following table lists the reference designators used on the XPD’s PMC(X) sites:

PMCX site	JN1	JN2	JN3	JN4
1 (also supports XMC)	J11	J12	J13	J14 (to P2)
2	J21	J22	J23	J24 (to P0)

4.4 VMEbus Chassis Installation

Unless your VMEbus chassis features automatic daisy chaining, it will have a set of five jumpers for each slot:

- **Interrupt Acknowledge** – IACKIN* and IACKOUT*
- **Bus Grant 0** – BG0IN* and BG0OUT*
- **Bus Grant 1** – BG1IN* and BG1OUT*
- **Bus Grant 2** – BG2IN* and BG2OUT*
- **Bus Grant 3** – BG3IN* and BG3OUT*

These jumpers are typically found between slots, and when configuring a VMEbus chassis, care must be taken to correctly determine the slot affected by the jumpers (the slot to the right of the jumpers). The interrupt acknowledge is a daisy chain from the board acknowledging the interrupt request to the boards that can issue an interrupt request. The bus grant signals are daisy chains from the system controller, which contains the bus arbiter, to the boards that can request the bus.

Empty VMEbus slots between boards should have all of these jumpers installed. Any slot containing the XPD should have all of these jumpers removed. Any VMEbus slots after the last board in the chassis (that is, the board farthest away from the system controller, which is always in slot 1) do not require these jumpers. For other boards in the VMEbus chassis, refer to their installation instructions for their jumper requirements.

Once the VMEbus chassis jumpers are installed, insert the XPD into its designated slot. With the XPD ejector handles inward, firmly push the XPD into the VMEbus connectors on the chassis. Tighten the screws to the outside of the ejector handles to complete the installation of the XPD in the VMEbus chassis.

4.5 Front Panel Connectors and Reset Switch

The XPD offers front panel connections for two USB ports and two RJ45 connector for 1000BaseTX Ethernet ports. Install all front panel cables by inserting them into the appropriate connector. COM1 and DVO/VGA cables can be secured to the XPD by tightening their thumbscrews into the connectors' jackscrews. USB and Ethernet mating connectors should snap into place. Mounting hardware for the front panel connectors are isolated from the XPD's digital ground. They are continuous with the front panel itself that, in turn, is common with chassis ground.

The XPD contains a recessed reset switch, accessible from the front panel. To reset the XPD, press the reset switch using a small screwdriver blade or similar implement.

The Ethernet connectors each have a pair of indicator LEDs built in. These two green LEDs offer stats on the 1000BaseTX port provided by the 82571EB Ethernet controller on the XPD.

- **Link** – Ethernet link is established when on. This LED is to the left (or top when the XPD is held vertically)
- **Activity** – Ethernet data is being transmitted from or received by the XPD when on. This LED is to the right/bottom of the Link LED.

A. Connector Pin-outs

The locations of the XPD connectors are shown below. The connectors that do not go to the front panel have their pin 1 location designated accordingly.

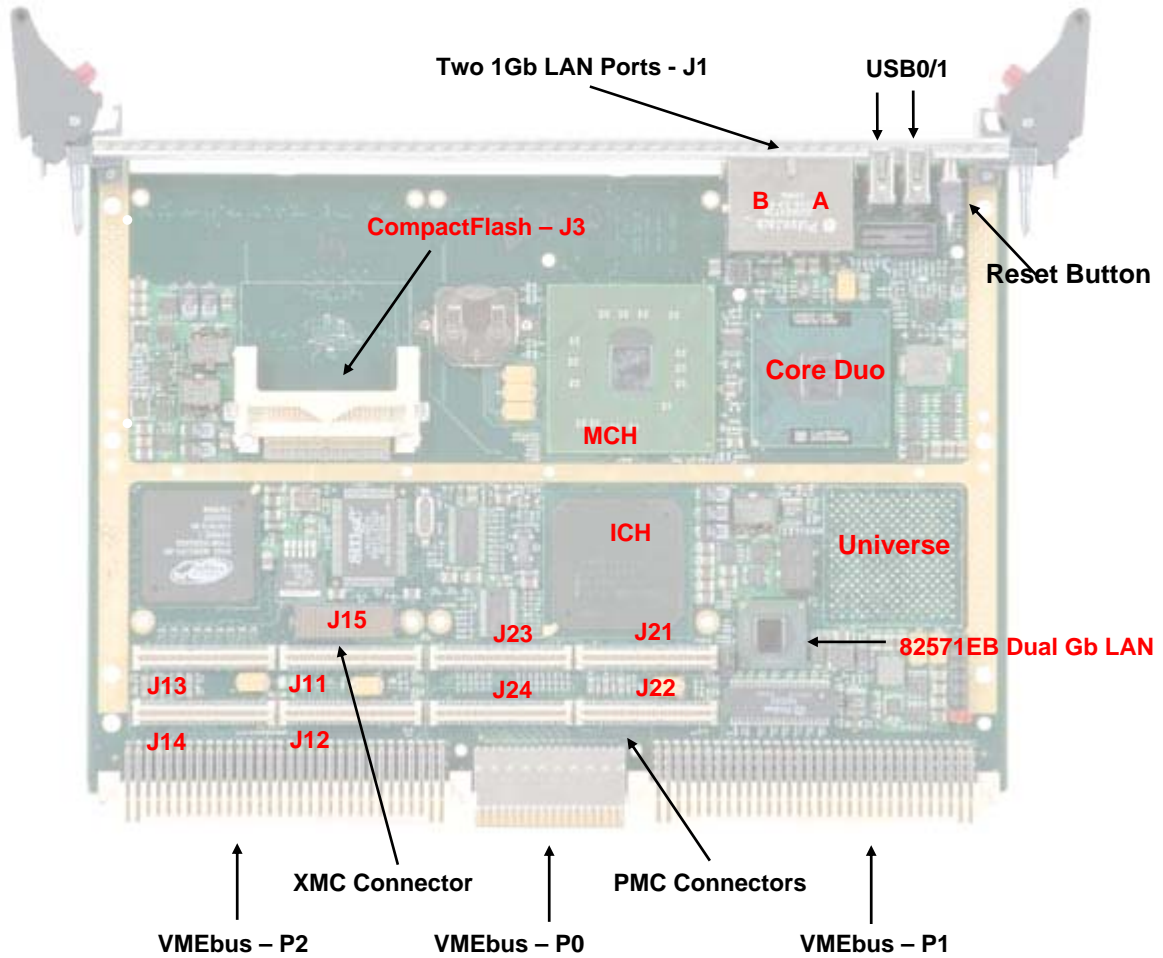

Appendix A – Connector Pin-outs

A.1 Front Panel USB Connector (USB1 & USB2)

There are two USB connectors (labeled USB1 & USB2) accessible at the XPD's front panel. Though they are separate ports, their pin-outs are identical so the following table offers the pin-out of one connector as both.

Pin	Signal Description
1	+5 VDC (via 1.1 amp self-resetting fuse F2)
2	Negative Data
3	Positive Data
4	Signal GND
5	Chassis GND
6	Chassis GND
7	Chassis GND
8	Chassis GND

USB Connectors (USB1 & USB2) – Front Panel USB Receptacles. The metal shell of the connector goes to chassis ground.

A.2 1000BaseTX Fast Ethernet Front Panel Connector (J1)

The XPD uses a dual RJ45 connector to provide two 1000BaseTX Ethernet ports at the front panel. Though there are two separate ports in one connector, the pin-outs are identical so the following table offers the pin-out of one connector as both.

Pin	Signal Description	Signal Description
1	Port A Transmit Data + (TX+)	TP0+
2	A Transmit Data - (TX-)	TP0-
3	A Receive Data + (RX+)	TP1+
4	Unused	TP2+
5	Unused	TP2-
6	A Receive Data - (RX-)	TP1-
7	Unused	TP3+
8	Unused	TP3-

1000BaseTX Fast Ethernet Connector (J1) – Front Panel RJ-45 Connector. The metal shell of the connector goes to chassis ground.

A.3 CompactFlash Interface Connector (J3)

Pin	Signal	Pin	Signal
1	GND	26	No connection
2	D3	27	D11
3	D4	28	D12
4	D5	29	D13
5	D6	30	D14
6	D7	31	D15
7	CS1#	32	CS3#
8	GND	33	No connection
9	GND	34	DIOR#
10	GND	35	DIOW#
11	GND	36	+5 VDC
12	GND	37	DIRQ (IRQ15)
13	+5 VDC	38	+5 VDC
14	GND	39	Pulled Low (master)
15	GND	40	No connection
16	GND	41	IDERESSET
17	GND	42	Pulled Up to 3.3 VDC
18	DA2	43	No connection
19	DA1	44	+5 VDC
20	DA0	45	No connection
21	D0	46	Pull-up to +5 VDC
22	D1	47	D8
23	D2	48	D9
24	No connection	49	D10
25	No connection	50	GND

CompactFlash Type II Interface Connector (J3)

Appendix A – Connector Pin-outs

A.4 VMEbus Connectors (P1, P2, and P0)

Pin	Signal	Pin	Signal	Pin	Signal	Pin	Signal	Pin	Signal
Z01	NC	A01	D00	B01	BBSY*	C01	D08	D01	+5 VDC
Z02	GND	A02	D01	B02	BCLR*	C02	D09	D02	GND
Z03	JTAG_TCK	A03	D02	B03	ACFAIL*	C03	D10	D03	NC
Z04	GND	A04	D03	B04	BG0IN*	C04	D11	D04	NC
Z05	JTAG_TDO	A05	D04	B05	BG0OUT*	C05	D12	D05	NC
Z06	GND	A06	D05	B06	BG1IN*	C06	D13	D06	NC
Z07	JTAG_TDI	A07	D06	B07	BG1OUT*	C07	D14	D07	NC
Z08	GND	A08	D07	B08	BG2IN*	C08	D15	D08	NC
Z09	JTAG_TMS	A09	GND	B09	BG2OUT*	C09	GND	D09	GAP#
Z10	GND	A10	SYSCLK	B10	BG3IN*	C10	SYSFAIL*	D10	GA0#
Z11	NC	A11	GND	B11	BG3OUT*	C11	BERR*	D11	GA1#
Z12	GND	A12	DS1*	B12	BR0*	C12	SYSRST*	D12	NC
Z13	NC	A13	DS0*	B13	BR1*	C13	LWORD*	D13	GA2#
Z14	GND	A14	WRITE*	B14	BR2*	C14	AM5	D14	NC
Z15	NC	A15	GND	B15	BR3*	C15	A23	D15	GA3#
Z16	GND	A16	DTACK*	B16	AM0	C16	A22	D16	NC
Z17	NC	A17	GND	B17	AM1	C17	A21	D17	GA4#
Z18	GND	A18	AS*	B18	AM2	C18	A20	D18	NC
Z19	NC	A19	GND	B19	AM3	C19	A19	D19	NC
Z20	GND	A20	IACK*	B20	GND	C20	A18	D20	NC
Z21	NC	A21	IACKIN*	B21	No connection (NC)	C21	A17	D21	NC
Z22	GND	A22	IACKOUT*	B22	No connection (NC)	C22	A16	D22	NC
Z23	NC	A23	AM4	B23	GND	C23	A15	D23	NC
Z24	GND	A24	A07	B24	IRQ7*	C24	A14	D24	NC
Z25	NC	A25	A06	B25	IRQ6*	C25	A13	D25	NC
Z26	GND	A26	A05	B26	IRQ5*	C26	A12	D26	NC
Z27	NC	A27	A04	B27	IRQ4*	C27	A11	D27	NC
Z28	GND	A28	A03	B28	IRQ3*	C28	A10	D28	NC
Z29	NC	A29	A02	B29	IRQ2*	C29	A09	D29	NC
Z30	GND	A30	A01	B30	IRQ1*	C30	A08	D30	NC
Z31	NC	A31	-12VDC/NC	B31	+5 VDC Standby	C31	+12VDC/NC	D31	GND
Z32	GND	A32	+5 VDC	B32	+5 VDC	C32	+5 VDC	D32	+5 VDC

VMEbus Connector (P1) – DIN 41612 96-pin (3 rows x 32 pins)

Appendix A – Connector Pin-outs

The XPD routes the primary IDE interface to the P2 connector's a and c rows while the middle row, row b, is used for the VMEbus' extended address and data bus. The IDE pins are in blue font.

Other I/O routed out through the P2 connector are two USB 2.0 ports, PS/2 Mouse & Keyboard, and four RS232 serial ports: two have full handshaking while the other two are just two-wire interfaces.

I/O pins from JN4 (connector P14) of the PMCX module are routed to rows d and z.

Pin	Signal	Pin	Signal	Pin	Signal	Pin	Signal	Pin	Signal
Z01	P14-2	A01	PDD7	B01	+5 VDC	C01	PDD8	D01	P14-1
Z02	GND	A02	PDD6	B02	GND	C02	PDD9	D02	P14-3
Z03	P14-5	A03	PDD5	B03	No Connect	C03	PDD10	D03	P14-4
Z04	GND	A04	PDD4	B04	A24	C04	PDD11	D04	P14-6
Z05	P14-8	A05	PDD3	B05	A25	C05	PDD12	D05	P14-7
Z06	GND	A06	PDD2	B06	A26	C06	PDD13	D06	P14-9
Z07	P14-11	A07	PDD1	B07	A27	C07	PDD14	D07	P14-10
Z08	GND	A08	PDD0	B08	A28	C08	PDD15	D08	P14-12
Z09	P14-14	A09	PIORDY	B09	A29	C09	PDDREQ	D09	P14-13
Z10	GND	A10	PDDACK#	B10	A30	C10	PDIOW#	D10	P14-15
Z11	P14-17	A11	IRQ14	B11	A31	C11	PDIOR#	D11	P14-16
Z12	GND	A12	PDA1	B12	GND	C12	PDA2	D12	P14-18
Z13	P14-20	A13	PDA0	B13	+5 VDC	C13	PDCS3#	D13	P14-19
Z14	GND	A14	PDCS1#	B14	D16	C14	USB_3N	D14	P14-21
Z15	P14-23	A15	BIT_OUT1	B15	D17	C15	USB_3P	D15	P14-22
Z16	GND	A16	BIT_OUT0	B16	D18	C16	PRI_RST#	D16	P14-24
Z17	P14-26	A17	BIT_CNTRL1	B17	D19	C17	USB_2N	C17	P14-25
Z18	GND	A18	BIT_CNTRL0	B18	D20	C18	USB_2P	D18	P14-27
Z19	P14-29	A19	EXT_RST#	B19	D21	C19	USB_V	D19	P14-28
Z20	GND	A20	+5 VDC	B20	D22	C20	GND	D20	P14-30
Z21	P14-32	A21	COM1-DCD	B21	D23	C21	COM2-DCD	D21	P14-31
Z22	GND	A22	COM1-DSR	B22	GND	C22	COM2-DSR	D22	P14-33
Z23	P14-35	A23	COM1-RxD	B23	D24	C23	COM2-RxD	D23	P14-34
Z24	GND	A24	COM1-RTS	B24	D25	C24	COM2-RTS	D24	P14-36
Z25	P14-38	A25	COM1-TxD	B25	D26	C25	COM2-TxD	D25	P14-37
Z26	GND	A26	COM1-CTS	B26	D27	C26	COM2-CTS	D26	P14-39
Z27	P14-41	A27	COM1-DTR	B27	D28	C27	COM2-DTR	D27	P14-40
Z28	GND	A28	COM1-RI	B28	D29	C28	COM2-RI	D28	P14-42
Z29	P14-44	A29	COM3-RxD	B29	D30	C29	COM4-RxD	D29	P14-43
Z30	GND	A30	COM3-TxD	B30	D31	C30	COM4-TxD	D30	P14-45
Z31	P14-46	A31	KBDATA	B31	GND	C31	MADATA	D31	GND
Z32	GND	A32	KBCLK	B32	+5 VDC	C32	MCLK	D32	+5 VDC

VMEbus Connector (P2) – 160-pin (5 rows x 32 pins)

Appendix A – Connector Pin-outs

Connector P0 routes two Gb Ethernet ports (in compliance with VITA 31.1), a VGA interface, and two Serial ATA ports.

The two Gb Ethernet ports occupy rows 2 through 5. To follow Vita 31.1 to the letter, rows 1 & 6 are all no connects and pins C02 through C05 are grounded. The XPD can comply to Vita 31.1 by the appropriate use of 0 ohm resistors but in the pin-out below these pins are used for two SATA ports and the VGA port.

Pin	Signal	Pin	Signal	Pin	Signal	Pin	Signal	Pin	Signal
A01	SATA1_TXN	B01	SATA1_TXP	C01	VGA_Red	D01	SATA0_TXN	E01	SATA0_TXP
A02	LPa_DA+	B02	LPa_DA-	C02	VGA_Green	D02	LPa_DC+	E02	LPa_DC-
A03	LPa_DB+	B03	LPa_DB-	C03	VGA_Blue	D03	LPa_DD+	E03	LPa_DD-
A04	LPb_DA+	B04	LPb_DA-	C04	VGA_HSYNC	D04	LPb_DC+	E04	LPb_DC-
A05	LPb_DB+	B05	LPb_DB-	C05	VGA_VSYNC	D05	LPb_DD+	E05	LPb_DD-
A06	SATA1_RXN	B06	SATA1_RXP	C06	VGA_ddcdata	D06	SATA0_RXN	E06	SATA0_RXP
A07	PIO5	B07	PIO4	C07	PIO3	D07	PIO2	E07	PIO1
A08	PIO10	B08	PIO9	C08	PIO8	D08	PIO7	E08	PIO6
A09	PIO15	B09	PIO14	C09	PIO13	D09	PIO12	E09	PIO11
A10	PIO20	B10	PIO19	C10	PIO18	D10	PIO17	E10	PIO16
A11	PIO25	B11	PIO24	C11	PIO23	D11	PIO22	E11	PIO21
A12	PIO30	B12	PIO29	C12	PIO28	D12	PIO27	E12	PIO26
A13	PIO35	B13	PIO34	C13	PIO33	D13	PIO32	E13	PIO31
A14	PIO40	B14	PIO39	C14	PIO38	D14	PIO37	E14	PIO36
A15	PIO45	B15	PIO44	C15	PIO43	D15	PIO42	E15	PIO41
A16	PIO50	B16	PIO49	C16	PIO48	D16	PIO47	E16	PIO46
A17	PIO55	B17	PIO54	C17	PIO53	D17	PIO52	E17	PIO51
A18	PIO60	B18	PIO59	C18	PIO58	D18	PIO57	E18	PIO56
A19	VGA_ddcclk	B19	PIO64	C19	PIO63	D19	PIO62	E19	PIO61

VME64 Extensions Bus Connector (P0) for XPD, Rev A (PWB D010 6065 001) – Row F is grounded

A.5 PCI-X Mezzanine Card Connectors (JN1, JN2, JN3, and JN4) and the XMC connector (J15)

This section has the pin-outs for all four PMC connectors. There are two PMC sites. Their pinouts are largely identical. When signals differ between the two PMC sites, **red font will be used for PMC Site 1** (see the photo at the beginning of Section 4 of this User’s Manual) and **blue font will be used for PMC Site 2**. JN4 pinouts for the two different sites, I/O connectors where the pins are routed to P2 & P0 respectively, are completely different for the two sites so these pinouts will be provided separately.

Pin	Signal	Pin	Signal
1	5.6K pull-down	2	-12 VDC
3	GND	4	PX_PIRQ0#/PX_PIRQ1#
5	PX_PIRQ1#/PX_PIRQ2#	6	PX_PIRQ2#/PX_PIRQ3#
7	No connection	8	+5 VDC
9	PX_PIRQ3#/PX_PIRQ0#	10	No connection
11	GND	12	No connection
13	PMC1CLK/PMC1CLK	14	GND
15	GND	16	GNT0#/GNT1#
17	REQ0#/REQ1#	18	+5 VDC
19	VI/O from JP3	20	AD31
21	AD28	22	AD27
23	AD25	24	GND
25	GND	26	C/BE3#
27	AD22	28	AD21
29	AD19	30	+5 VDC
31	VI/O from JP3	32	AD17
33	FRAME#	34	GND
35	GND	36	IRDY#
37	DEVSEL#	38	+5 VDC
39	PCIXCAP	40	LOCK#
41	No connection	42	No connection
43	PAR	44	GND
45	VI/O from JP3	46	AD15
47	AD12	48	AD11
49	AD9	50	+5 VDC
51	GND	52	C/BE0#
53	AD6	54	AD5
55	AD4	56	GND
57	VI/O from JP3	58	AD3
59	AD2	60	AD1
61	AD0	62	+5 VDC
63	GND	64	REQ64#

PCI-X Mezzanine Card (PMCX) Connector (JN1) – Molex 71439-0164

VIO is jumper selectable through JP3 (please see Section 4.1).

Appendix A – Connector Pin-outs

Pin	Signal	Pin	Signal
1	+12 VDC	2	TRST (pulled down)
3	TMS (pulled up)	4	No connection
5	TDI (pulled up)	6	GND
7	GND	8	No connection
9	No connection	10	No connection
11	+3.3 VDC	12	+3.3 VDC
13	PCI RST#	14	GND
15	+3.3 VDC	16	GND
17	No connection	18	GND
19	AD30	20	AD29
21	GND	22	AD26
23	AD24	24	+3.3 VDC
25	(IDSEL) AD17/AD18	26	AD23
27	+3.3 VDC	28	AD20
29	AD18	30	GND
31	AD16	32	C/BE2#
33	GND	34	No connection
35	TRDY#	36	+3.3 VDC
37	GND	38	STOP#
39	PERR#	40	GND
41	+3.3 VDC	42	SERR#
43	C/BE1#	44	GND
45	AD14	46	AD13
47	M66EN	48	AD10
49	AD8	50	+3.3 VDC
51	AD7	52	No connection
53	+3.3 VDC	54	No connection
55	No connection	56	GND
57	No connection	58	No connection
59	GND	60	No connection
61	ACK64#	62	+3.3 VDC
63	GND	64	No connection

PCI-X Mezzanine Card (PMCX) Connector (JN2) – Molex 71439-0164

Pin	Signal	Pin	Signal
1	No connection	2	GND
3	GND	4	C/BE7#
5	C/BE6#	6	C/BE5#
7	C/BE4#	8	GND
9	VIO	10	PAR64
11	AD63	12	AD62
13	AD61	14	GND
15	GND	16	AD60
17	AD59	18	AD58
19	AD57	20	GND
21	VIO	22	AD56
23	AD55	24	AD54
25	AD53	26	GND
27	GND	28	AD52
29	AD51	30	AD50
31	AD49	32	GND
33	GND	34	AD48
35	AD47	36	AD46
37	AD45	38	GND
39	VIO	40	AD44
41	AD43	42	AD42
43	AD41	44	GND
45	GND	46	AD40
47	AD39	48	AD38
49	AD37	50	GND
51	GND	52	AD36
53	AD35	54	AD34
55	AD33	56	GND
57	VIO	58	AD32
59	No connection	60	No connection
61	No connection	62	GND
63	GND	64	No connection

PCI-X Mezzanine Card (PMCX) Connector (JN3) – Molex 71439-0164

Appendix A – Connector Pin-outs

Pin	Signal	Pin	Signal
1	D1	2	Z1
3	D2	4	D3
5	Z3	6	D4
7	D5	8	Z5
9	D6	10	D7
11	Z7	12	D8
13	D9	14	Z9
15	D10	16	D11
17	Z11	18	D12
19	D13	20	Z13
21	D14	22	D15
23	Z15	24	D16
25	D17	26	Z17
27	D18	28	D19
29	Z19	30	D20
31	D21	32	Z21
33	D22	34	D23
35	Z23	36	D24
37	D25	38	Z25
39	D26	40	D27
41	Z27	42	D28
43	D29	44	Z29
45	D30	46	Z31
47	No connection	48	No connection
49	No connection	50	No connection
51	No connection	52	No connection
53	No connection	54	No connection
55	No connection	56	No connection
57	No connection	58	No connection
59	No connection	60	No connection
61	No connection	62	No connection
63	No connection	64	No connection

PCI-X Mezzanine Card (PMCX) Site #1 Connector (J14) – Molex 71439-0164

J14 is the JN4 I/O connector for PMC Site #1. These lines will be routed to the D & Z rows of the P2 backplane connector.

Pin	Signal	Pin	Signal
1	E7	2	D7
3	C7	4	B7
5	A7	6	E8
7	D8	8	C8
9	B8	10	A8
11	E9	12	D9
13	C9	14	B9
15	A9	16	E10
17	D10	18	C10
19	B10	20	A10
21	E11	22	D11
23	C11	24	B11
25	A11	26	E12
27	D12	28	C12
29	B12	30	A12
31	E13	32	D13
33	C13	34	B13
35	A13	36	E14
37	D14	38	C14
39	B14	40	A14
41	E15	42	D15
43	C15	44	B15
45	A15	46	E16
47	D16	48	C16
49	B16	50	A16
51	E17	52	D17
53	C17	54	B17
55	A17	56	E18
57	D18	58	C18
59	B18	60	A18
61	E19	62	D19
63	C19	64	B19

PCI-X Mezzanine Card (PMCX) Site #2 Connector (J24) – Molex 71439-0164

J24 is the JN4 I/O connector for PMC Site #2. These lines will be routed to the pins shown for the P0 backplane connector.

Appendix A – Connector Pin-outs

Following is the pinout for the XMC connector associated with PMC/XMC Site #1. The XMC site routes x8 PCI Express to the mezzanine card.

Pin	Column A	Column B	Column C	Column D	Column E	Column F
1	PETp0B	PETn0B	3.3 VDC	PETp1B	PETn1B	5 VDC
2	Ground	Ground	TRST# pulled low	Ground	Ground	PCI_RST#
3	PETp2B	PETn2B	3.3 VDC	PETp3B	PETn3B	5 VDC
4	Ground	Ground	TCK pulled low	Ground	Ground	No Connect
5	PETp4B	PETn4B	3.3 VDC	PETp5B	PETn5B	5 VDC
6	Ground	Ground	TMS pulled high	Ground	Ground	12 VDC
7	PETp6B	PETn6B	3.3 VDC	PETp7B	PETn7B	5 VDC
8	Ground	Ground	TDI pulled high	Ground	Ground	-12 VDC
9	No Connect	No Connect	No Connect	No Connect	No Connect	5 VDC
10	Ground	Ground	No Connect	Ground	Ground	Ground
11	PERp0B	PERn0B	No Connect	PERp1B	PERn1B	5 VDC
12	Ground	Ground	Ground	Ground	Ground	No Connect
13	PERp2B	PERn2B	3.3 VDC	PERp3B	PERn3B	5 VDC
14	Ground	Ground	Ground	Ground	Ground	No Connect
15	PERp4B	PERn4B	No Connect	PERp5B	PERn5B	5 VDC
16	Ground	Ground	No Connect	Ground	Ground	No Connect
17	PERp6B	PERn6B	No Connect	PERp7B	PERn7B	No Connect
18	Ground	Ground	No Connect	Ground	Ground	No Connect
19	CLK100P_XMC	CLK100N_XMC	No Connect	No Connect	No Connect	No Connect

XMC Bus Connector (J15) for XPD, Rev A (PWB D010 6065 001)

B. BIOS & Setup

The DPD uses General Software's Embedded BIOS with StrongFrame™ Technology, Rev 6. The BIOS is configured with the System Setup Utility, accessible from the Preboot Menu. This photo shows the initial splash screen that is displayed after powering up the system as the BIOS runs through the Power On Self Test (POST). When your system is powered on, Embedded BIOS tests and initializes the hardware and programs the chipset and other peripheral components.

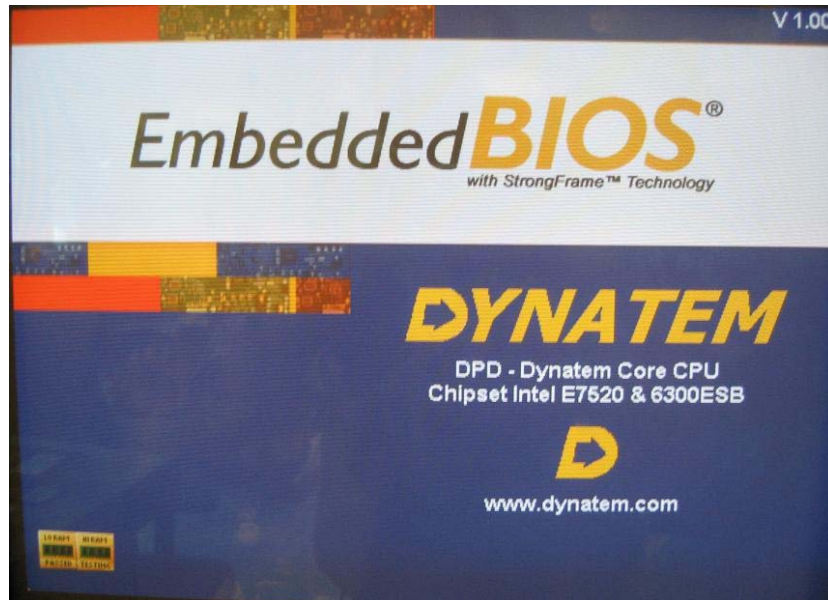

To enter the Setup mode, please press the delete key on your keyboard after powering up your system, during POST.

B.1 Redirecting to a Serial Port

Setup may be run from the main keyboard and video display or from a terminal emulator program running on a host computer connected to the system through a serial cable. To use a serial port, connect a dumb terminal or a PC running a terminal emulation utility like Hyperterminal to COM1 via a null modem. Next, set the communications parameters of the host's terminal program to 115Kbaud. Other parameters are 8-bit, no parity, and one stop bit. Do not enable XON/XOFF or hardware flow control.

With this link set up, power on the system. Press ^C a few times on your dumb terminal or your PC as the system boots. POST will redirect to the serial console, and after it has completed its early stages, it will start the preboot menu.

B.2 Setup Menus

The standard Embedded BIOS setup menus are described below in the order they generally appear in the menuing system (**Dynatem cannot vouch for support for all BIOS functions described in the subsequent sections**):

Main	Display main system components and allow editing of date and time.
Exit	Save changes and exit, discard changes and exit, or restore factory default settings.
Boot	Configure boot actions and boot devices.
POST	Configure POST.
PnP	Configure Plug-n-Play for non-ACPI OSes.
SIO	Configure Super I/O devices such as serial ports and parallel ports.
Features	Enable and disable system BIOS features like ACPI, APM, PnP, MP, quick boot, and

Appendix B – BIOS & Setup

	the splash screen.
Firmware	Configure Firmware Technology and the features that use it, such as USB keyboard and mouse support (commonly, USB HID), boot from USB (commonly, USB Boot), and applications such as high availability, boot security (not user security, but chain-of-trust security), and network-based remote access.
Misc	Configure miscellaneous BIOS settings that do not fall into any other category.
Shadowing	Configure chipset shadow RAM regions.
Security	Configure which BIOS features require user authentication before they perform their functions
CUI	Configure the layout and coloring of the Common User Interface (CUI) display engine that supports preboot applications.
Chipset	Configure any chipset-specific parameters, such as memory, CPU, and bus timing, and availability of chipset-specific features such as TFT support. Highly platform-specific and entirely up to the OEM's implementation.

B.3 Navigating Setup Menus and Fields

Navigation (moving your cursor around, selecting items, and changing them) is easy in the Setup system. The following chart is a helpful user reference:

UP key (also ^E)	Move the cursor to the line above, scrolling the window as necessary.
DOWN key (also ^X)	Move the cursor to the line below, scrolling the window as necessary.
LEFT key	Go back to the menu to the left of the currently-displayed menu in the menu bar.
RIGHT key	Go forward to the menu to the right of the currently-displayed menu in the menu bar.
PGUP key	Move the cursor up several lines (a full window's worth), scrolling the window as necessary.
PGDN key	Move the cursor down several lines (a full window's worth), scrolling the window as necessary.
HOME key	Move the cursor to the first configurable field in the current menu, scrolling the window as necessary.
END key	Move the cursor to the last configurable field in the current menu, scrolling the window as necessary.
ESC key	Exit the Setup system, discarding all changes(except date/time changes, which take place on-the-fly.)
TAB key	Move the cursor down to the next configurable field.
Shift-TAB key (backtab)	Move the cursor up to the last configurable field.
+ key	Toggle an Enable/Disable field, or increase a numeric field's value.
- key	Toggle an Enable/Disable field, or decrease a numeric field's value.
SPACE key	Toggle an Enable/Disable field.
BKSP key	Reset an Enable/Disable or multiple-choice field, or back-up in numeric or string fields.
Digits (0-9)	Used to enter numeric parameters.
Alphabetic (A-Z, a-z)	Used to enter text data on ASCII fields such as email addresses.
Special symbols (!@#\$%^&* _+={}[] , etc.)	Used to enter special text on ASCII fields that permit these characters.

The basic idea when using the Setup system is to navigate to the menus containing fields you want to review, and change those fields as desired. When your settings are complete, navigate to the EXIT menu, and select "Save Settings and Restart". This causes the settings to be stored in nonvolatile memory in the system, and the system will reboot so that POST can configure itself with the new settings.

After rebooting it may be desirable to reenter the Setup system as necessary to adjust settings as necessary. Once the system boots, the Setup system cannot be entered; this is because the memory used by the BIOS configuration manager is deallocated by the system BIOS, so that it can be used by the OS when it boots. To reenter the Setup system after boot, simply reset the system or power off and power back on.

B.4 Main Setup Menu

The first menu always showing in the Setup system is the Main menu (unless disabled by the OEM.) This menu is shown in Figure 3.1 below.

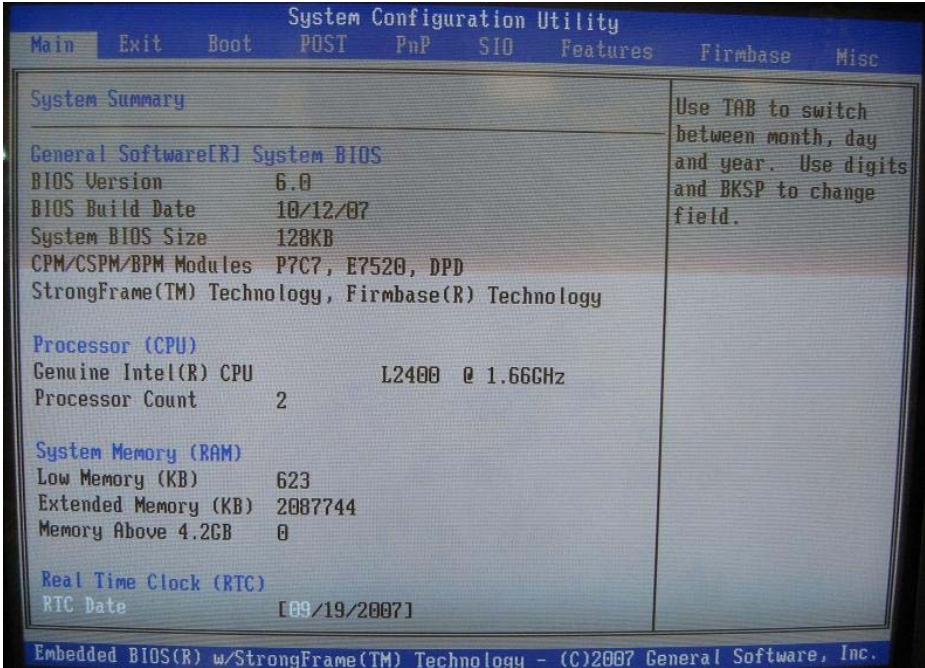

The Main menu provides a system summary about the BIOS, processor, system memory, date and time, and any other items configured by the OEM. The BIOS information is obtained by Setup from the internal system BIOS build itself; this information is useful when obtaining support for your system.

PLEASE CALL Dynatem at (800)543-2830 FOR BIOS SUPPORT; DO NOT CALL GENERAL SOFTWARE DIRECTLY.

BIOS Version	Indicates the major and minor core architecture versions (6.x, where x is a number from 0 to 999.)
BIOS Build Date	Date in MM/DD/YY format on which Dynatem built the system BIOS binary file.
System BIOS Size	Size of BIOS exposed in low memory below the 1MB boundary. Commonly, 128KB would mean that the BIOS is visible in the address space from E000:0000 to F000:FFFF.
CPM/CSPM/BPM Modules	Indicates the names of the key architectural modules used to create the system BIOS binary file. The CPM module provides the CPU family support; the CSPM module provides the northbridge support; and the BPM module provides the board-level support.

The CPU information is normally obtained by querying the Processor Brand String in the CPU’s MSRs; the method used to achieve this is beyond the scope of this document.

The system memory information does not describe physical RAM; rather it describes the RAM as configured, subtracting RAM used for System Management Mode, Shadowing, Video buffers, and other uses. This provides realistic values about how much memory is actually available to operating systems and applications.

The Real Time Clock fields are editable with keystrokes. To navigate through the MM/DD/YYYY and HH:MM:SS fields, use the TAB and BACKTAB keys. The hours are normally specified in military time; thus 13 means 1pm, or

Appendix B – BIOS & Setup

one hour after noon, whereas 01 means 1am, or one hour after midnight. When the cursor leaves RTC fields, they either affect the battery-backed RTC right away, allowing the system to continue with your new settings, or they revert back to old values if the new values are not valid entries.

B.5 Exit Setup Menu

The Exit menu provides methods for saving changes made in other menus, discarding changes, or reloading the standard system settings. This menu is shown in Figure 3.2 below.

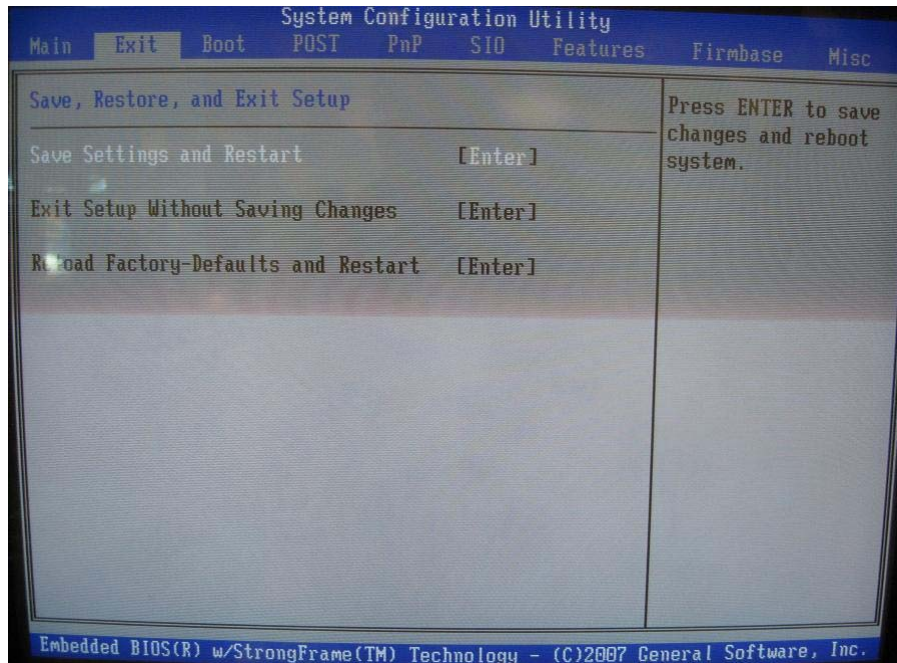

To select any of these options, position the cursor over the option and press the ENTER key. Pressing the ESC key at any time within the Setup system is equivalent to requesting “Exit Setup Without Saving Changes.”

B.6 Boot Setup Menu

The Boot menu allows the system’s boot actions and boot devices to be configured. This menu is shown here:

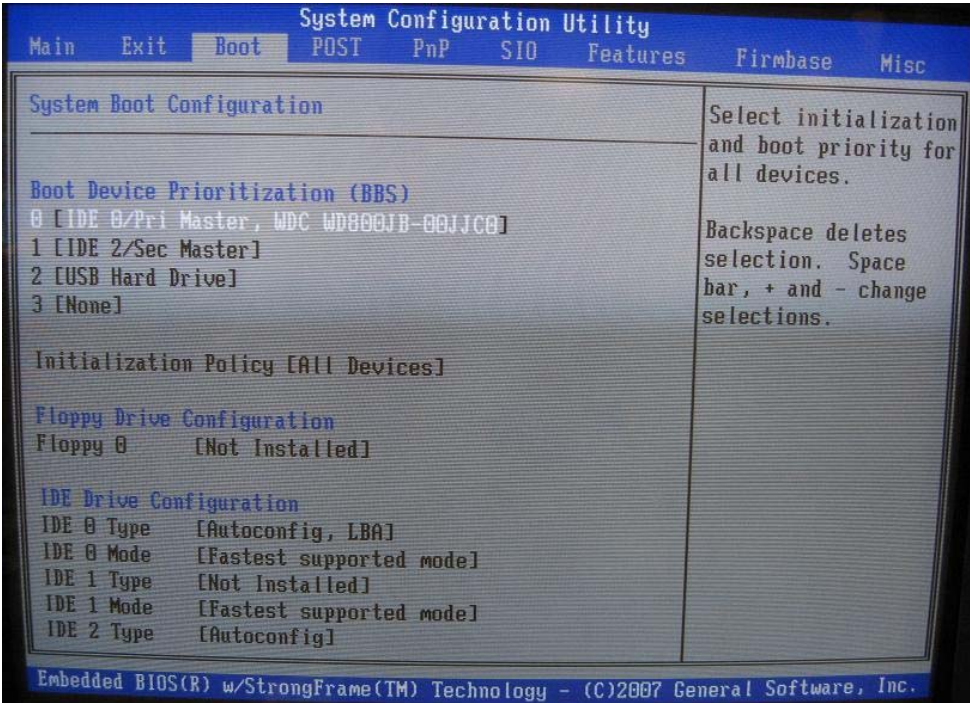

The BBS portion of this menu lists the devices and activities to be performed in the order in which they appear in the list. When the BIOS completes POST, it follows this list, attempting to process each item. Some items are drives, such as an ATA/IDE drive, or a USB hard disk, or CDROM.

The ordering of the drives in the BBS list controls the BIOS in several ways. First, it is the list of drives that is scanned and assigned BIOS unit numbers for DOS (for example 80h, 81h, 83h, and so on for hard drives). If a drive on the list is not plugged in or working properly, the BIOS moves on to the next drive, skipping the inoperative one.

Second, once the drives in the list have been verified, POST attempts to boot from them in that order as well. Drives without bootable partitions might be configured, but skipped over in the boot phase, so that other drives on the list become candidates for booting the OS.

The BBS list also contains other boot actions, such as boot from network cards and PCI slots, as well as special BIOS boot actions like “Boot EFI”, “Boot Windows CE”, or even “Boot Debugger”. When deciding what boot action to do first and then next in succession, POST first scans all the drives in the list to verify they are present and operating properly (as described earlier in this section) and then goes down the list and tries to perform the actions in order. During this boot phase, if the list item is a drive, an attempt is made to boot from the boot record of that drive. If the list item is a device like a network card or PCI slot, an attempt is made to boot from that device. If the list item is a software item like “Boot Debugger”, then it performs that action, and when that action completes, it moves on to the next item in the BBS list.

The table that follows lists the set of standard boot action items:

“drive name” – The system BIOS may list the drive’s name in a generic sense (i.e., “USB Hard Drive”) if the drive has not been detected yet, or the drive’s full manufacturing name and serial number (if detected.)	Boot from the MBR/PBR of the named BIOSaware IPL drive (BAID). The drive may be Legacy Floppy, PATA, SATA, Compact Flash, or a USB drive.
IDE0/Primary Master Primary	Master PATA drive or SATA mapping by the chipset, routed

Appendix B – BIOS & Setup

	to the backplane via P2.
IDE1/Primary Slave	Primary Slave PATA drive or SATA mapping by the chipset, routed to the backplane via P2.
IDE2/Secondary Master	Secondary Master PATA drive or SATA mapping by the chipset, routed to on-board CompactFlash
IDE CDROM	First detected IDE CDROM.
USB Floppy Drive	First detected USB floppy drive.
USB Hard Drive	First detected USB hard drive.
USB CDROM Drive	First detected USB CDROM.
Enter Board Information Browser	Invoke HTML Browser on 0.HTM in ROM.
Enter BIOS Setup Screen	Invoke System Setup Utility in ROM.
Enter BIOS Debugger	Invoke BIOS debugger in ROM.
Reboot System	Restart system.
Power Off System	Invoke S5 state, powering off system.
PCI Slot [n]	Boot from device in PCI Slot 'n'.
Network	Boot from any network adapter.
SCSI	Boot from external SCSI device (on PMC/XMC card).
Boot EFI Binary	Boot EFI kernel from ROM or disk, depending on the EFI source setting in the Features menu. If disk is selected, then the BIOS searches all the configured disks in the system in the order they appear in the BBS list, attempting to load EFILDR.BIN from the root directory in the FAT file system located on those drives.
Boot Windows CE Image	Boot Windows CE kernel from disk. The BIOS searches all the configured disks in the system in the order they appear in the BBS list, attempting to load NK.BIN from the root directory in the FAT file system located on those drives.
Boot Graphical Desktop	Boot Firmbase GUI supporting graphical Firmbase applications as well as booting DOS in a graphical window. For applications requiring instant-on functionality even when the OS is not available or is still loading.

The photograph above shows a common setup of the BBS list for desktop applications. In this example, the first boot device is the Western Digital IDE hard drive (WDC WD800JB-00JJC0) connected to the target as a Primary Master IDE drive. The second boot device is the Secondary Master and this is the on-board CompactFlash. The third device is a USB Hard Drive. A fourth boot device, "None", is a placeholder that is simply used to add more entries in the setup screen; "None" is not actually executed by POST as a boot action item.

In addition to the BBS boot device list, there are two more sections in the BOOT menu; namely, the Floppy Drive Configuration and IDE Drive Configuration sections. Both of these sections tell the BIOS what kind of equipment is connected to the motherboard but **the floppy drive interface has not been implemented so please ignore this** and leave it as "Not Installed". Similarly, the IDE Drive Configuration section describes the type of hard drive equipment that is connected to the motherboard, including the cable type. IDE drives, or actually more properly Parallel ATA (PATA) drives, are connected to the motherboard with a flat cable with either 40 or 80 wires running in parallel (hence, Parallel ATA, as opposed to Serial ATA.) The 40-pin connector supports speeds up to UDMA2, whereas 80-pin cables are needed for higher transfer rates to eliminate noise. The BIOS can be told what type of cable is available, so that it knows whether higher transfer rates are allowed; or, it can be told to autodetect the cable type, in which case the drive and the motherboard must both support the hardware protocol used to autodetect the drive's cable type.

Note: PATA cable autodetection sometimes fails with older drives, so 40-pin is the default, to ensure data integrity. For higher performance, you should change this setting to 80-pin or AUTO if an 80-pin cable is installed.

B.7 POST Setup Menu

The POST menu is used to configure POST. This menu is shown in the following figure (scrolled down more so the full set of options can be seen.) Be sure to review the Features menu, where additional items can be configured, such as the Splash Screen and BIOS initiatives.

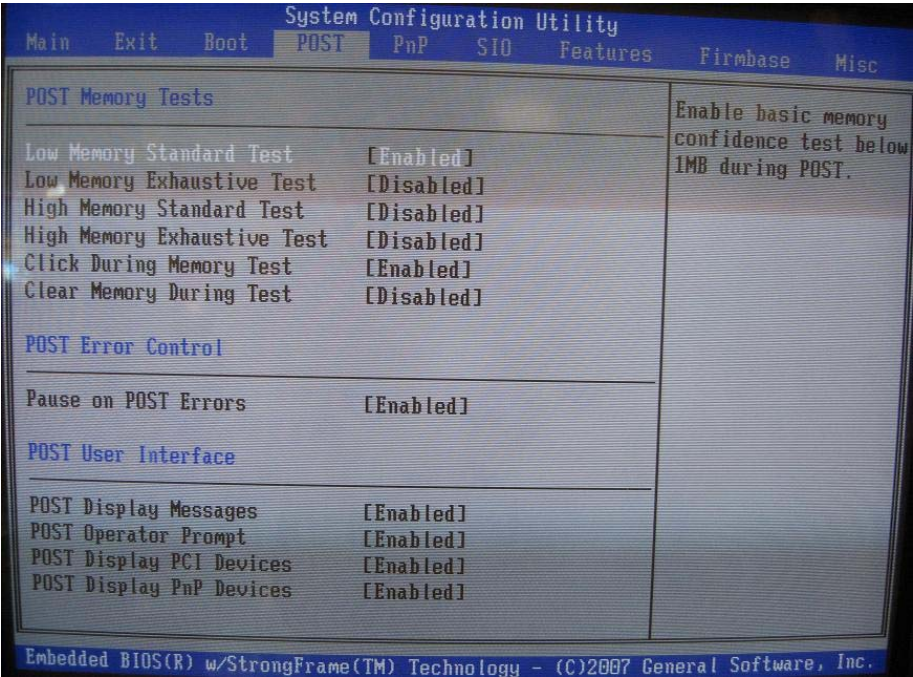

The figure below shows the same menu, scrolled down so that the remainder of its fields may be viewed.

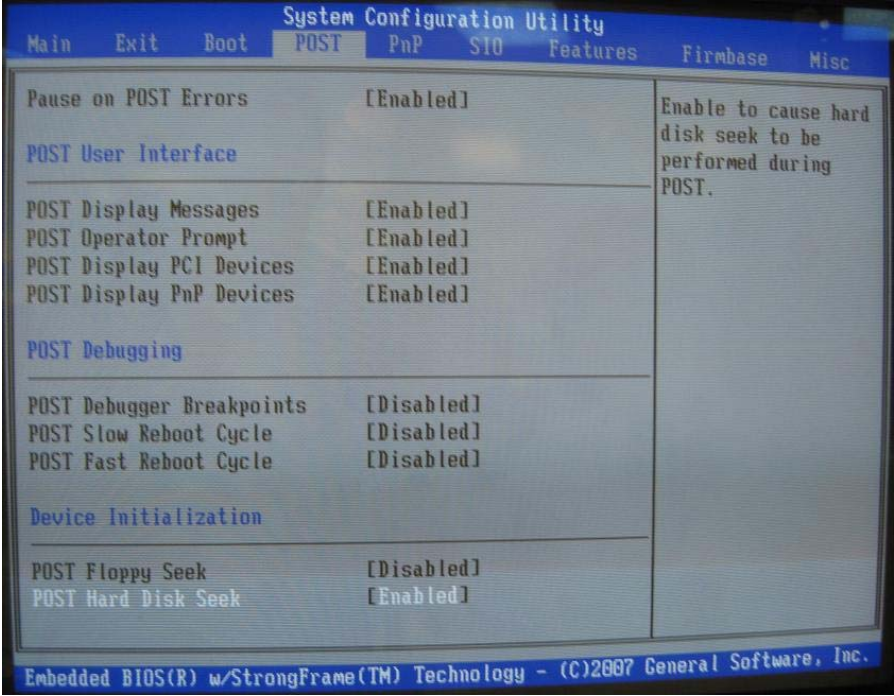

Appendix B – BIOS & Setup

The following table describes the settings associated with the POST setup menu's Memory Test section.

Low Memory Standard Test	Enable basic memory confidence test, of memory below 1MB address boundary (conventional memory, or memory normally used by DOS.)
Low Memory Exhaustive Test	Enable exhaustive memory confidence test of memory below 1MB address boundary.
High Memory Standard Test	Enable basic memory confidence test, of memory between 1MB and 4.2GB address boundaries (extended memory.)
High Memory Exhaustive Test	Enable exhaustive memory confidence test, of memory between 1MB and 4.2GB address boundaries.
Huge Memory Standard Test	Enable basic memory confidence test, of memory above 4.2GB address boundary (available using PAE technology.)
Huge Memory Exhaustive Test	Enable exhaustive memory confidence test, of memory above 4.2GB address boundary.
Click During Memory Test	Enable/disable speaker click when testing each block.
Clear Memory During Test	Enable storing 0's in all memory locations tested. Only necessary when some legacy DOS programs are run, as they may rely on cleared memory to operate properly.

The following table describes the settings associated with the POST setup menu's Error Control section:

Pause on POST Errors	Enable pause when errors are detected during POST, so that the user can view the error message and enter Setup or continue to boot the OS.
----------------------	--

The following table describes the settings associated with the POST setup menu's POST User Interface section:

POST Display Messages	Enable display of text messages during POST. When disabled, POST is "quiet."
POST Operator Prompt	Enable operator prompts if POST is configured to ask interactive questions of the user about whether to load specific features; i.e., whether or not to load SMM.
POST Display PCI Devices	Enable display of PCI devices.
POST Display PnP Devices	Enable display of ISA PnP devices.

The following table describes the settings associated with the POST setup menu's Debugging section:

POST Debugger Breakpoints	Enable processing of INT 3 (breakpoint) instructions embedded into option ROMs. When enabled, if an INT 3 instruction is encountered, control is transferred to the BIOS debugger, so that the option ROM can be debugged. When disabled, these instructions perform no action.
POST Fast Reboot Cycle	Enable early reboot in POST, allowing service technician to verify that the hardware can technician to verify that the hardware can reboot very quickly many times in succession. Platform will continue to reboot after every boot until the system's CMOS is reset, as there is no way to enter Setup from this early point during POST.
POST Slow Reboot Cycle	Enable late reboot in POST, allowing service technician to cause the system to move through POST and then reboot, causing POST to be reexecuted, over and over, until Setup is reentered and this option is disabled. When left unattended, this is a straightforward way of having POST exercise system memory and peripherals without requiring a boot to a drive with an operating system installed.

The following table describes the settings associated with the POST setup menu's Device Initialization section:

POST Floppy Seek	Enable head seek on each floppy drive configured in the system. Used to recalibrate the drive in some systems with older DOS operating systems.
POST Hard Disk Seek	Enable head seek on each hard drive configured in the system. This is a way of extending the standard testing performed on each drive during POST, by requesting that the drive actually move the head. Not available with all drives.

B.8 PnP Setup Menu

The PnP menu is used to configure Plug-n-Play, a legacy BIOS initiative used to support operating systems such as Windows95, Windows98, and WindowsNT. ACPI has largely replaced this feature; however, it is necessary for platforms to support older operating systems.



The PnP menu consists of two sections; basic configuration that enables Plug-n-Play and identifies if a PnP should perform configuration or let the OS do it; and then, another section that defines which system IRQs should be reserved for PnP’s use, so that PCI doesn’t use them. The following table presents the fields in the PnP menu.

Plug-n-Play	Enable PnP feature. When disabled, a PnPaware OS will not find any PnP services in the BIOS, and all other configuration parameters in the menu will be greyed out. Enable to support legacy OSES like DOS, Windows95, Windows98, and WindowsNT. Disable for operating systems like WindowsXP or Windows Vista, or for Linux operating systems with ACPI support.
Plug-n-Play OS	Enable delay of configuration of PnP hardware and option ROMs. When enabled, BIOS will NOT configure the devices, and instead defer assignment of resources, such as DMA, I/O, memory, and IRQs, to the PnP OS. When disabled, the BIOS performs conflict detection and resolution, and assigns resources for the OS. Disable this parameter when running non-PnP OSES like DOS. Enable this parameter when running PnP OSES like Windows95, Windows98, and WindowsNT.
IRQ0	Enable exclusive use of IRQ0 by PnP.
IRQ1	Enable exclusive use of IRQ1 by PnP.
IRQ2	Enable exclusive use of IRQ2 by PnP.
IRQ3	Enable exclusive use of IRQ3 by PnP.
IRQ4	Enable exclusive use of IRQ4 by PnP.
IRQ5	Enable exclusive use of IRQ5 by PnP.
IRQ6	Enable exclusive use of IRQ6 by PnP.
IRQ7	Enable exclusive use of IRQ7 by PnP.
IRQ8	Enable exclusive use of IRQ8 by PnP.
IRQ9	Enable exclusive use of IRQ9 by PnP.
IRQ10	Enable exclusive use of IRQ10 by PnP.
IRQ11	Enable exclusive use of IRQ11 by PnP.

Appendix B – BIOS & Setup

IRQ12	Enable exclusive use of IRQ12 by PnP.
IRQ13	Enable exclusive use of IRQ13 by PnP.
IRQ14	Enable exclusive use of IRQ14 by PnP.
IRQ15	Enable exclusive use of IRQ15 by PnP.

B.9 Super I/O (SIO) Setup Menu

The SIO menu is used to configure the LPC47B27x Super I/O device. The only implemented I/O on this chip are the PS/2 mouse and keyboard and two 2-wire COM ports (COM3 & COM4). Basically this window is used to configure COM3 & COM4 (though they are referred to as Serial Ports 1 & 2 in the SIO Setup Menu):

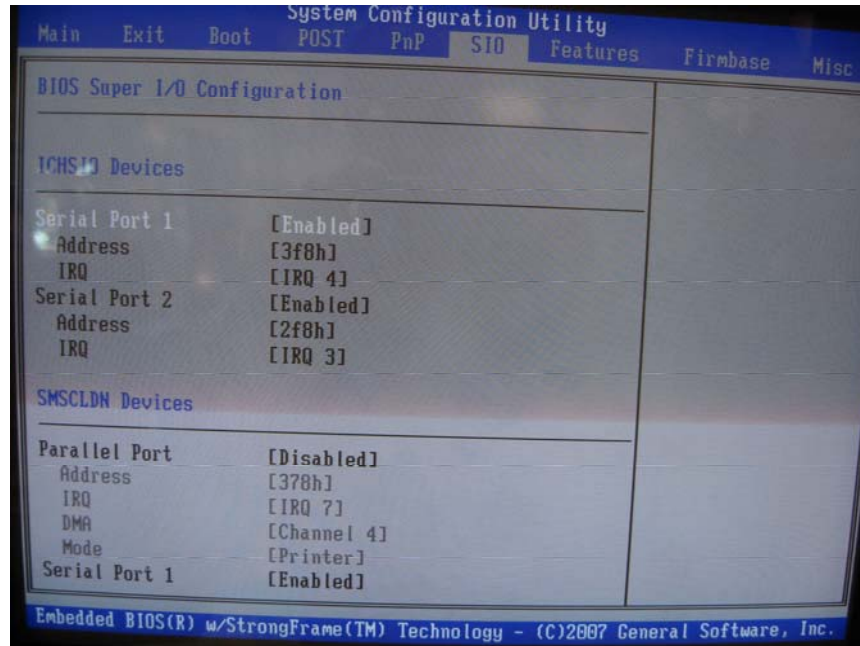

POST reads these settings in the menu shown above and programs the Super I/O part accordingly, enabling and disabling devices as requested. The disabled devices are not further programmed, since they are actually disabled in hardware. In the figure above, legacy I/O addresses and IRQs are as follows:

COM3 – I/O 3f8h, IRQ4.

COM4 – I/O 2f8h, IRQ3.

It should be noted that these are not the only possible addresses, but they are the ones that will ensure compatibility with the most legacy software, especially early DOS programs that do not use BIOS to access the COM ports.

B.10 Features Setup Menu

The Features menu is used to configure the system BIOS’ major features, including Quick Boot, APM, ACPI, PMM, SMBUS, SMBIOS, Manufacturing Mode, Splash Screen, Console Redirection, and others added by the OEM. This figure shows a typical Features Setup menu.

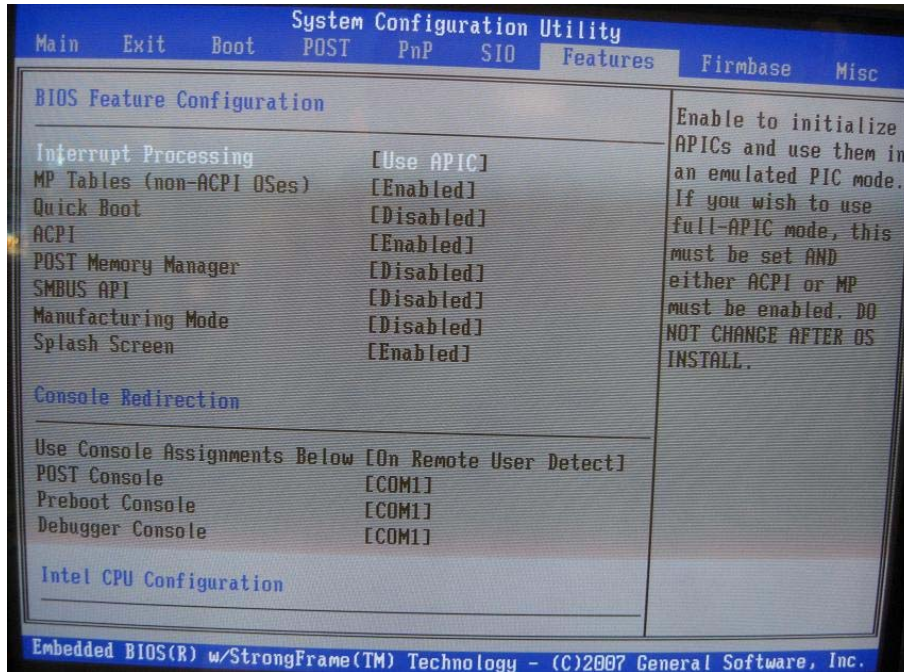

The following table describes each setting in the Features menu :

Quick Boot	Enable time-optimized POST, causing certain preconfigured OEM optimizations to be made when the system boots. Depending on the system, Quick Boot can reach the DOS prompt in as little as 85ms (milliseconds.)
Advanced Power Management (APM)	Enable legacy power management, used by the system when an ACPI-aware operating system is not running (during POST, such as when the system is running the preboot environment, or while running DOS, Windows95, Windows98, or Linux kernels below version 2.6.) Uses the SMM feature (see Firmware) to operate properly.
ACPI	Enable ACPI system description and power management (ACPI replaces PnP and APM.) Used with ACPI-aware OSes such as Linux kernels version 2.6 and above, Windows XP, and Windows Vista. Commonly also uses the SMM feature (see Firmware) to operate properly.
POST Memory Manager (PMM)	Enable memory allocation services for option ROMs, especially network cards running PXE. Some option ROMs may use this interface incorrectly, causing system crashes. Other PXE option ROMs may not run if PXE is not supported. Because of the state of these option ROMs, the setting is provided as an option to the user.
SMBUS API	Enable INT 15h services that permit certain software to access devices on the system’s SMBUS without having knowledge of the SMBUS controller itself.
System Management BIOS (SMBIOS)	Enable System Management BIOS interface specification support, exposing information about the type of hardware, including the chassis, motherboard layout, type of CPU and DRAM sticks, to applications such as WfM, which runs on PXE in the preboot environment.
Manufacturing Mode	Enable automatic entry into manufacturing mode when POST encounters a critical error. Used in closed device settings such as smart phones that need access to docking stations when they don’t boot. Leave disabled.
Splash Screen	Enable graphical POST
Console Redirection	Configure the console redirection feature over a serial port. Automatic – causes

	POST, the debugger, and the preboot environment to use the system's first serial port (COM1) when an RS232 cable is detected with DSR and CTS modem signals active, indicating a terminal emulation program is likely to be attached to the other end of the cable. Always – causes the BIOS to always use the serial port as the console, without testing for the presence of the terminal emulation program. Never – causes the BIOS to never invoke console redirection, but instead always use the main keyboard and video display. If there is no keyboard or video display, the system operates headless.
EFI Source	Configure the location (ROM or disk) where the EFI boot action can find the EFILDR.BIN image. An image may be merged with the system BIOS into the system ROM, or it may be placed in the root directory of any bootable mass storage device.

B.11 Firmware Setup Menu

The Firmware menu configures the Firmware Technology component of the system BIOS, including all of the features enabled by it; i.e., legacy USB keyboard and mouse, boot from USB devices, and support of Firmware applications such as Boot Security, Platform Update Facility, and High Availability Monitor. This menu has several parts, with the most basic user oriented feature options in the top section, and the more technical tuning parameters located in the lower sections.

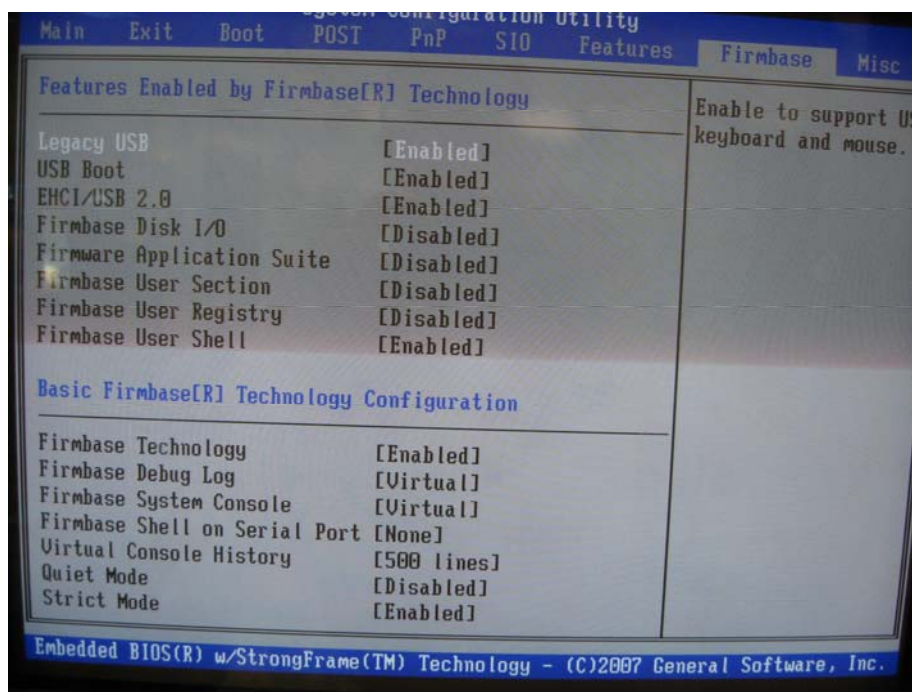

The following table presents the settings that enable high-level features enabled by Firmware Technology:

Legacy USB	Enables BIOS support for USB keyboards and mice. Up to 8 USB keyboards and 8 USB mice may be supported at a time. Use of PS/2 keyboard and mouse concurrently with USB devices is discouraged, as the legacy PS/2 keyboard controller cannot easily separate simultaneous data streams from both device classes.
USB Boot	Enables BIOS support for accessing USB mass storage devices and emulating legacy floppy, hard drive, and CDROM drive devices with them. Enable this option in order for USB devices to be supported in the BBS device list(see the BOOT menu.)
EHCI/USB 2.0	Enables EHCI Firmware Technology driver, allowing USB Boot feature to use high speed transfers on USB 2.0 ports in the system.

Firmware Disk I/O	Enables Firmware Technology FAT file system driver, so that Firmware applications such as Boot Security, Platform Update Facility, and HA Monitor, as well as the HA and TCB components of the kernel, have access to files residing on drives containing FAT file systems. Also turn on this option if you wish to run Firmware applications from FAT file systems on either ATA or USB mass storage devices.
Firmware Application Suite	Enables Firmware applications configured for the system by the OEM. Typically includes Boot Security, Platform Update Facility, and High Availability Monitor.
Firmware User Registry	Not used.
Firmware User Shell	Enables Firmware Technology command line interpreter, a multi-user command shell with DOS-like and Unix-like command structure; can be used to start Firmware applications written with the Firmware SDK, a General Software product.
Firmware Technology	Enables Firmware Technology as a whole, the industry's most comprehensive and full-featured System Management Mode (SMM) operating environment. Some hardware platforms require Firmware Technology to run, as they may use it to virtualize hardware such as virtual video and audio PCI devices. Some BIOS features, such as ACPI and APM, may require Firmware Technology to operate.
Firmware Debug Log	<p>Specifies the device used by Firmware Technology components (kernel, drivers, and programs) to display debugging instrumentation produced with the dprintf and DPRINTF system functions.</p> <p>None – Instrumentation disabled. COM1 – Write text to 1st serial port. COM2 – Write text to 2nd serial port. COM3 – Write text to 3rd serial port. COM4 – Write text to 4th serial port. Virtual – Write text to virtual console</p> <p>If enabled, this console can provide diagnostic messages (similar to the types displayed by Linux when it boots) for Firmware Technology features such as USB HID and USB Boot.</p>
Firmware System Console	<p>Specifies the device used by Firmware Technology's system process when it initializes the kernel and processes the [SYSTEM] registry section, including its Start and Run commands.</p> <p>None – System console disabled. COM1 – Write text to 1st serial port. COM2 – Write text to 2nd serial port. COM3 – Write text to 3rd serial port. COM4 – Write text to 4th serial port. Virtual – Write text to virtual console</p> <p>If enabled, this console can provide a list of sign-on banners of all Firmware applications loaded during system initialization.</p>
Firmware Shell on Serial Port	<p>Specifies a serial port that may be used by Firmware Technology's command line interpreter as an extra user session for systems that do not have a keyboard or monitor to support virtual consoles.</p> <p>None – Serial console disabled. COM1 – Console on 1st serial port. COM2 – Console on 2nd serial port. COM3 – Console on 3rd serial port. COM4 – Console on 4th serial port.</p>
Virtual Console History	Specifies the number of lines of text that Firmware Technology maintains in its virtual

Appendix B – BIOS & Setup

	console feature, allowing the user to scrollback through lines previously displayed and scrolled off the screen. OEMs may configure a set of values, such as 20, 50, 100, 200, and 500 lines.
Quiet Mode	Enables a feature that causes the Firmware kernel to suppress its standard messages to the system console.
Strict Mode	Enables a feature that causes the Firmware kernel to abort any processes in the system that make software errors in calling system API functions. Examples include blocking at IRQs other than IRQ_THREAD, or passing a NULL pointer to a C library function that requires a non-NULL pointer, etc. Disabling this feature causes the kernel to skip over the activity that discovered the programming error in the application, allowing it to continue if at all possible, with the consequence that the program may not operate correctly.

B.12 Miscellaneous Setup Menu

The Misc menu provides for configuration of BIOS settings that don't easily fit in any other category. They include Cache Control, Keyboard Control, Debugger Settings, and System Monitor Utility Configuration parameters.

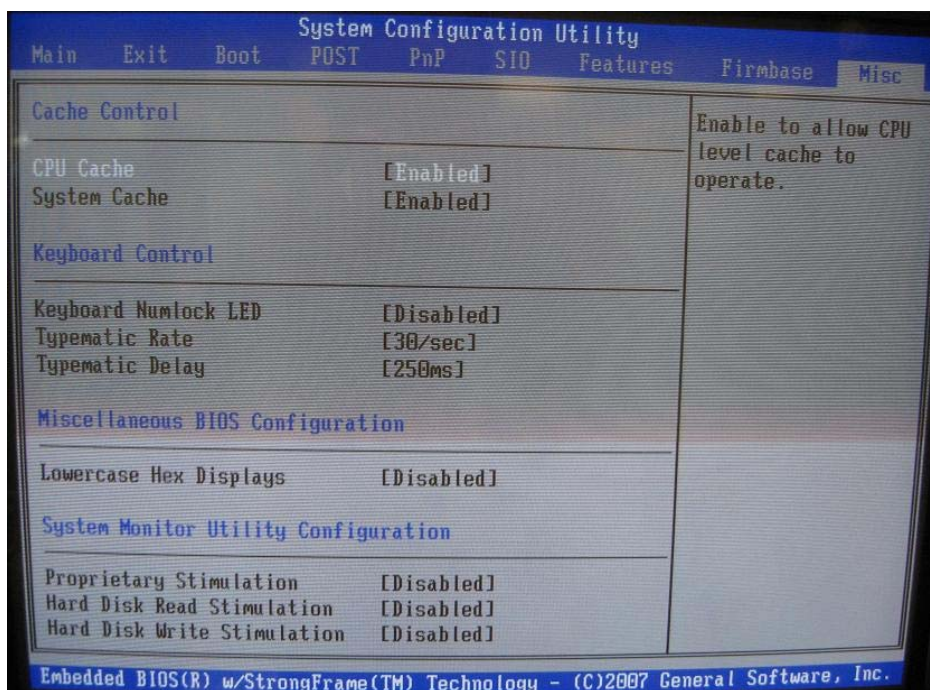

The following table presents the settings in the Misc Setup menu:

System Cache	Enables POST's support for cache in the system. Modern processors virtually require cache to be enabled to achieve acceptable performance. However, to diagnose certain problems related to caching in the system, such as multiprocessing systems, it may be desirable to disable this setting.
Keyboard Numlock LED	Enables the Numlock key when POST initializes the PS/2 keyboard.
Typematic Rate	Specify the rate at which the PS/2 keyboard controller repeats characters when most keys are pressed down. USB typematic is automatic and does not use this parameter.
Typematic Delay	Specifies the amount of time a repeating key may be pressed on a PS/2 keyboard until the key repeat feature begins repeating the keystroke. USB typematic is automatic and does not use this parameter.
Lowercase Hex Displays	Enables the display of hexadecimal numbers in the debugger with lowercase letters instead of uppercase letters (ie, 2f8ah instead of 2F8AH.)

Proprietary Stimulation	Enables System Monitor's callout to the OEM's BPM adaptation code to execute code that causes stimulation of the SMM environment for measurement purposes.
Hard Disk Read Stimulation	Enables System Monitor's read of a preconfigured number of sectors from a location on the first hard disk in the system in order to stimulate the SMM environment. This is useful when measuring code path lengths in USB boot, when the first hard drive is configured in the BBS list as a USB hard drive.
Hard Disk Write Stimulation	<p>Enables System Monitor's write of a preconfigured number of sectors to a location on the first hard disk in the system in order to stimulate the SMM environment. This is useful when measuring code path lengths in USB boot, when the first hard drive is configured in the BBS list as a USB hard drive.</p> <p>Please note that when this parameter is selected, the system automatically enables reading, so that the stimulation of the system includes reading a range of sectors into a memory buffer, and writing the same data back to the same range of sectors for safety. Thus, this feature is theoretically nondestructive.</p> <p>WARNING: YOU ARE ADVISED THAT THIS FEATURE COULD CAUSE DATA LOSS AT YOUR SOLE EXPENSE; ACCORDINGLY, IT IS PROVIDED AS-IS WITHOUT WARRANTY OF ANY KIND. ALWAYS BACKUP YOUR DATA BEFORE PERFORMING DIAGNOSTICS ON ANY SYSTEM, AS THEY COULD CAUSE DATA LOSS.</p>
Floppy Disk Read Stimulation	There is no Floppy Drive interface implemented on the DPD.

C. Power and Environmental Requirements

The XPD power and environmental requirements are shown in the tables below.

Condition	Power Requirements
1.66 GHz Core Duo	+5 VDC @ 6.0 A typ. 3.0 VDC Lithium Coin Cell @ 3.4 μ A

Power Requirements

The 3 Volt lithium coin cell is a CR2032 with 190 mAh capacity and it is used to battery-back the Real Time Clock, the 2 MB of NV-SRAM, and the BIOS's NV-RAM. At 3.4 μ A this battery should last for over six years with power off.

Condition	Environmental Requirements
Operating Temperature	-20 to 85° C with Thermal Monitor II enabled
Storage Temperature	-50° to +105° C

Environmental Requirements

D. XPDPTB Rear Plug-in I/O Expansion Module for the XPD

Dynatem offers a rear plug-in paddle card for I/O expansion with the XPD. Essentially the XPDPTB routes the XPD's backplane I/O, including IDE, COM1/2/3/4, P/S2 Mouse/Keyboard interfaces, VGA, two USB ports, and two SATA ports to industry standard connectors.

IDE, the four COM ports, two USB ports, and mouse and keyboard ports are routed through P2. The two Ethernet ports, two SATA ports, and the VGA port are routed through P0.

Two Serial ATA ports are routed through RP0. The XPDPTB also routes two VITA 31.1 compliant 1 Gb Ethernet ports from RP0 to two industry standard connectors for situations where VITA 31.1 backplane fabric switching is not used.

The Super I/O device used for COM3/4, P/S2 Mouse/Keyboard, LPT1, and FDC is SMSC's LPC47B272 and a data sheet can be found at: <http://www.smsc.com/main/catalog/lpc47b27x.html>

Here is a photograph of the XPDPTB with the connectors indicated:

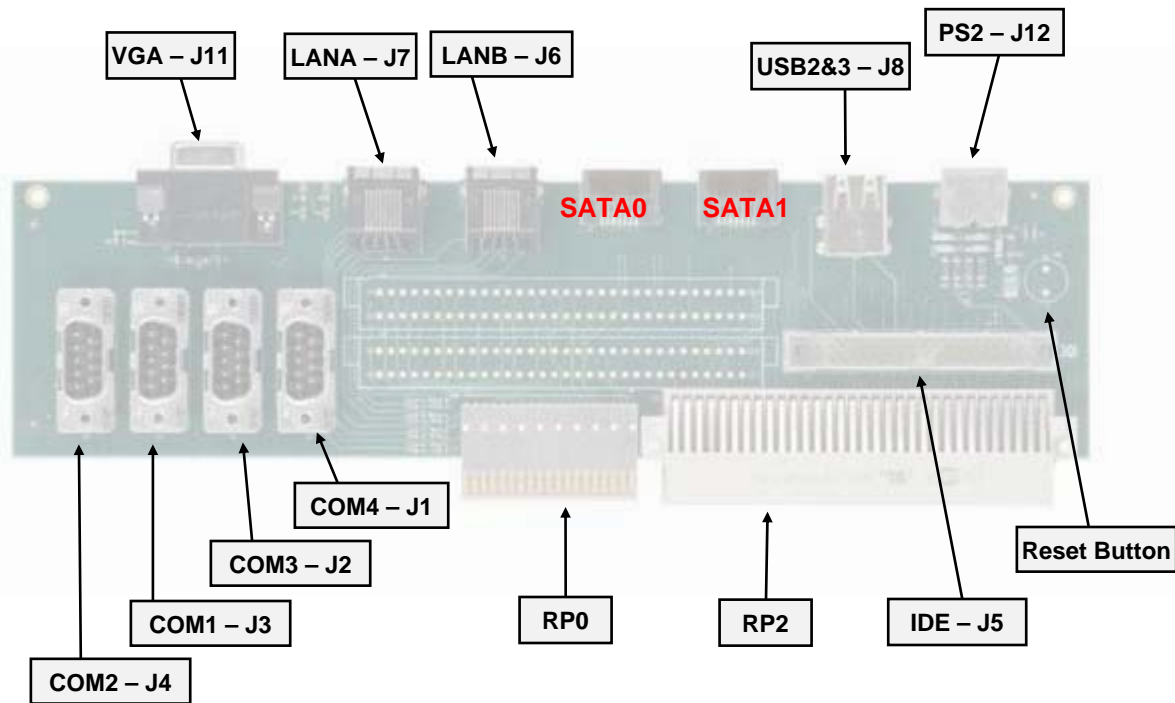

D.1 XPDPTB Connector Pinouts

Pin	Signal	Pin	Signal
1	RST#	2	GND
3	D7	4	D8
5	D6	6	D9
7	D5	8	D10
9	D4	10	D11
11	D3	12	D12
13	D2	14	D13
15	D1	16	D14
17	D0	18	D15
19	GND	20	No connection
21	DMARQ0	22	GND
23	IOW#	24	GND
25	IOR#	26	GND
27	IORDY	28	470-ohm pull-down
29	DMAACK0	30	GND
31	IRQ14	32	No connection
33	DA1	34	No connection
35	DA0	36	DA2
37	CS1Fx	38	CS3Fx
39	LED Control	40	GND

Primary IDE Interface Connector (J5) – 40-pin Dual-row 0.1” Header

COM1 and COM2 ports are set up for RS-232 operation. J3 is used for COM1 and J4 is used for COM2. The pinouts of the two connectors are identical:

Pin	RS-232 Signals
1	Data Carrier Detect (DCD) Input
2	Received Data (RxD) Input
3	Transmitted Data (TxD) Output
4	Data Terminal Ready (DTR) Output
5	GND
6	Data Set Ready (DSR) Input
7	Request To Send (RTS) Output
8	Clear To Send (CTS) Input
9	Ring Indicator (RI) Input

COM1 (J3) and COM2 (J4) Connectors – DB9M Connector. The metal shell of the connector goes to chassis ground.

Appendix D – XPDPTB Rear Plug-in I/O Expansion Module for the XPD

COM3 and COM4 ports are set up for two-wire RS-232 operation. J2 is used for COM3 and J1 is used for COM4. The pinouts of the two connectors are identical:

Pin	RS-232 Signals
1	No Connect
2	Received Data (RxD) Input
3	Transmitted Data (TxD) Output
4	No Connection
5	GND
6	No Connect
7	No Connect
8	No Connect
9	No Connect

COM3 (J2) and COM4 (J1) Connectors – DB9M Connector. The metal shell of the connector goes to chassis ground.

J9 (SATA1) and J10 (SATA0) are Serial ATA connectors where both ports have the following pinout:

Pin	Signal
1	GND
2	A+
3	A-
4	GND
5	B-
6	B+
7	GND

Serial ATA Connectors (J9, J10) - Pinout for either of the connectors

J12 combines the PS/2 Mouse and Keyboard interfaces on one connector. A Y-splitter cable is required to separate them.

Pin	Signal Description
1	Keyboard Data
2	Mouse Data
3	GND
4	+5 VDC (via 1 amp self-resetting fuse F1)
5	Keyboard Clock
6	Mouse Clock

Keyboard/Mouse Connector (J12) –Mini-DIN Receptacle. The metal shell of the connector goes to chassis ground.

Appendix D – XPDPTB Rear Plug-in I/O Expansion Module for the XPD

The XPDPTB uses two RJ45 connectors to provide two 1 Gb Ethernet ports. These lines are routed through 0 ohm resistors R1 – R16. These ports are also routed to the P0 connector in compliance with VITA 31.1. Leave the resistors off in systems that utilize Vita 31.1 backplane networking.

J7		
Pin	10/100 Signal Description	Gb Signal Description
A1	Port A Transmit Data + (TX+)	TP0+
A2	A Transmit Data - (TX-)	TP0-
A3	A Receive Data + (RX+)	TP1+
A4	Unused	TP2+
A5	Unused	TP2-
A6	A Receive Data - (RX-)	TP1-
A7	Unused	TP3+
A8	Unused	TP3-
J6		
Pin	10/100 Signal Description	Gb Signal Description
B1	Port B Transmit Data + (TX+)	TP0+
B2	B Transmit Data - (TX-)	TP0-
B3	B Receive Data + (RX+)	TP1+
B4	Unused	TP2+
B5	Unused	TP2-
B6	B Receive Data - (RX-)	TP1-
B7	Unused	TP3+
B8	Unused	TP3-

10BaseT/100BaseTX Fast Ethernet Connector (J7/J6) – RJ45 Connectors. The metal shell of the connectors go to chassis ground.

J8 is a dual-USB connector. Each connector has the same pinout as shown in Section A.3.